



INSTALLATION MANUAL

Fancoil Duct Type

MKT4-V200FG12-CL (KFC-PD-4T-200D3)

MKT4-V300FG12-CL (KFC-PD-4T-300D3)

MKT4-V500FG12-CL (KFC-PD-4T-500D3)

MKT4-V700FG12-CL (KFC-PD-4T-700D3)

MKT4-V1000FG12-CL (KFC-PD-4T-1000D39)

MKT4-V1200FG12-CL (KFC-PD-4T-1200D3)

Original instructions.

Please read this manual carefully and keep it for future reference.

All the pictures in this manual are for illustrations purpose only.



RECOGNIZE THIS SYMBOL AS AN INDICATION OF IMPORTANT SAFETY INFORMATION

⚠ WARNING

These instructions are intended as an aid to qualified licensed service personnel for proper installation, adjustment and operation of this unit. Read these instructions thoroughly before attempting installation or operation. Failure to follow these instructions may result in improper installation, adjustment, service or maintenance possibly resulting in fire, electrical shock, property damage or personal injury.

CONTENTS

1. ABOUT THE DOCUMENTATION.....	01
2. FUNCTIONS & FEATURES.....	02
3. ACCESSORIES.....	02
4. OPERATION RANGE.....	02
5. INSTALLATION INFORMATION.....	02
6. PARTS NAMES.....	04
7. INSTALLATION.....	04
8. PIPE CONNECTION.....	07
9. INSTALLATION DRAINAGE PIPE.....	07
10. WIRING.....	08

1. ABOUT THE DOCUMENTATION

1.1 About this document



NOTE

Make sure that the user has the printed documentation and ask him/her to keep it for future reference.

Target audience

Authorised installers + end users



NOTE

This appliance is intended to be used by expert or trained users in shops, in light industry, and on farms, or for commercial and household use by lay persons.



WARNING

Please thoroughly read and ensure that you fully understand the safety precautions (including the signs and symbols) in this manual, and follow relevant instructions during use to prevent damage to health or property.

Documentation set

This document is part of a documentation set. The complete set consists of:

- General safety precautions:
Safety instructions that you must read before installing
- Fan coil unit(s) installation and operation manual:
Installation and operation instructions
- Controller installation and operation manual:
Installation and operation instructions

Please refer to the product manual for other accessories.

Technical engineering data

Latest revisions of the supplied documentation may be available via your dealer.

The original documentation is written in English. All other languages are translations.

1.2 Safety precautions

Please thoroughly read and ensure that you fully understand the safety precautions (including the signs and symbols) in this manual, and follow relevant instructions during use to prevent damage to health or property.

Safety Signs

DANGER

Indicates a hazard with a high level of risk which, if not avoided, will result in serious injury.

WARNING

Indicates a hazard with a medium level of risk which, if not avoided, could result in serious injury.



CAUTION

Indicates a hazard with a low level of risk which, if not avoided, could result in minor or moderate injury.

NOTE

Useful operation and maintenance information.

Explanation Of Symbols Displayed On The Unit

	CAUTION	This symbol shows that the operation manual should be read carefully.
	CAUTION	This symbol shows that a service personnel should be handling this equipment with reference to the installation manual.
	CAUTION	This symbol shows that information is available such as the operating manual or installation manual.

WARNING

- Ask professional staff to install (install for the first time, change the place of the unit or re-install) and repair the unit and its parts. The installation operator must have acquired the relevant professional qualification. Do not attempt to install or repair the air conditioner by yourself, as any improper operations may lead to fire, electric shock, personal injury or water leakage.
- The installation height of the unit shall be at least 2.5m above the ground. Otherwise, an accident may occur.
- Make sure the unit is grounded reliably in accordance with the laws. Otherwise, it may cause electric shock.
- Stop using the air conditioner and consult your dealer in case of any abnormalities. Otherwise, fire or electric shock may occur.
- Do not attempt to maintain or alter the unit by yourself. Improper operations may cause water leakage, electric shock or fire.
- Make sure the leakage protection device is installed, or electric shock may occur.
- Do not wash the unit with water, or electric shock may occur.
- To avoid electric shock, do not place any water-filled container on the unit.
- Do not operate the switch with wet hands, or electric shock may occur.
- Do not put your fingers or other objects into the unit, it can result in serious injury.
- Do not obstruct the air supply channel, it may result in personal injury or damages to the unit.
- Check that the supporting structure of the unit is securely installed after a long period of use, to prevent fall accidents.
- Make sure the installation base and hoisting are robust and reliable; otherwise, the unit may fall and lead to accidents.
- Do not expose yourself to cold air over a long period. Too low temperature may cause harm to your health.
- Do not expose animals or plants to air outlet to avoid any harm.
- Do not install the unit where flammable gas may leak. Otherwise, fire may occur. Do not install the unit in potentially explosive atmospheres.
- Keep the unit far away from combustible spray to avoid fire.
- Use proper fuse. Do not use iron wire or copper wire, as it may cause fire or unit abnormality.
- When connecting power supply to the unit, follow the regulations of the local electric company.
- Provide separate power switch to ensure the unit can be disconnected from power properly.
- Do not use this unit to store spare parts or other items.
- Please attach enough importance to the signs and symbols indicated on the unit. Any other potential hazards not covered in the Manual (if any) should be specified in labels attached to the unit.
- If the supply cord is damaged, it must be replaced by the manufacturer or its service agent or a similarly qualified person in order to avoid a hazard.

NOTE

- Read the Manual carefully and perform a safety inspection in advance so that you can be fully aware of the possible dangers as you use or install the unit.
- The manufacturer shall not be liable for any personal or animal injury or damage to any object caused by incorrect installation, adjustment, maintenance or improper use.
- The manufacturer is not held liable for any damages resulting from faulty operations against this Manual.
- Do not expose this unit to wet or humid environments as this may damage electrical components.
- Do not store this unit in the open air. Do not stack unpackaged units.
- Do not use this unit to store food, plants, precision instruments, artwork etc.
- To operate the unit for the first time, exhaust the air in the coil; otherwise, the performance may be compromised.
- Clean the inside of the water pipe before use.
- Remember to implement anti-freezing measures for coil in winter. For details, please refer to anti-freezing instructions herein.
- Keep the unit energized even if it is not in service over a long period.
- Adopt self-protection measures when you install, maintain or clean the unit.
- Do not press the unit. Handle it carefully as any damages may cause unit malfunction.
- Reserve enough space for installation and maintenance.
- Before installation, check whether the unit is reliably grounded. Otherwise, do not proceed with the installation. In no circumstances can the earth line for main power switch be disconnected.
- Rotate the fan impeller during installation. Contact the manufacturer if you hear any abnormal noises.
- Make sure that the water discharge pipeline can provide smooth drainage. Improper installation of the water discharge pipeline may lead to water leakage, and damages to furniture.
- Make sure the liquid pipeline and air duct are reliably supported. Make sure pipes and connectors are not distorted.
- The water inlet and outlet pipes must have check valves installed and be wrapped with insulation materials.
- Connect the wires as required. Otherwise, it may cause damage to electrical parts.
- The actual power supply must be consistent with the nominal nameplate value, or permanent damage may occur.
- Use power cord with a proper diameter.
- Do not use damaged cables. Replace the damaged cables immediately if necessary. Do not attempt to repair the damaged cables.
- Keep for future reference.

2 FUNCTIONS & FEATURES

- Nested in the ceiling, space-saving and noble.
- High capacity of cooling / heating performance, high efficiency and energy-saving
- Adjust the indoor temperature rapidly and averagely.
- Low noise design.
- The air outlet is laid out in the way you desire.

3 ACCESSORIES

Table 4-1

Accessory Name	Qty	Sharp	Purpose
Installation manual	1	This manual	——
Accessional plastic water tray	1		——

4 OPERATION RANGE

Use the system in the following temperature for safe and effective operation.

Table 5-1

Temperature Mode	Room temperature	Water inlet temperature
Cooling operation	17 °C to 32 °C	3 °C to 20 °C
Heating perating (Optional)	0 °C to 30 °C	30 °C to 80 °C

5 INSTALLATION INFORMATION

To install properly, please read this Installation manual at first.

The air conditioner must be installed by qualified persons.

When installing the fan coil unit(s) or its tubing, please follow this manual as strictly as possible. If the air conditioner is installed on a metal part of the building, it must be electrically insulated according to the relevant standards to electrical appliances.

When all the installation work is finished, please turn on the power only after a thorough check. Regret for no further announcement if there is any change of this manual caused by product improvement.

NOTE

- If air conditioner is used outside the above conditions, it may cause the unit to function abnormally.
- The phenomenon is normal that the surface of air conditioning may condense water when the relative larger humidity in room, please close the door and window.
- Optimum performance will be achieved within these operating temperature range.
- Water system operating pressure: Max: 1.6 MPa, Min: 0.15 MPa.

6 PARTS NAMES

The above figures is an instance models, which would be different from the one that you purchase.

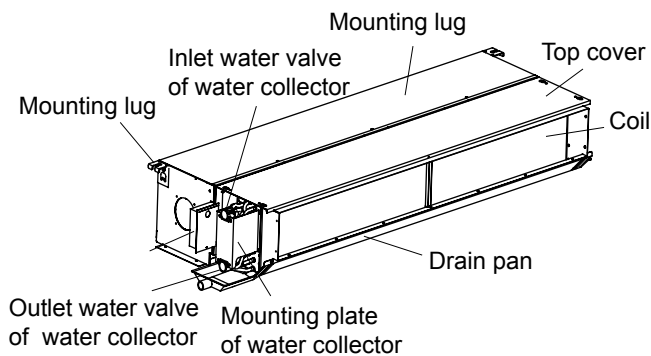

Fig. 6-1

7 INSTALLATION

7.1 Installing site

- Install the unit where enough space of installation and maintenance is available.
- Install the unit where the ceiling is horizontal and enough for bearing the weight of the fan coil unit(s).
- Install the unit where the air inlet and outlet are not baffled and are the least affected by external air.
- Install the unit where the supply air flow can be sent to all parts in the room.
- Install the unit where it is easy to lead out the connective pipe and the drain pipe.
- Install the unit where connotative heat is emitted from a heat source directly.

CAUTION

Installing the equipment in any of the following places may lead to faults of the equipment (if that is inevitable, consult the supplier):

- The site contains mineral oils such as cutting lubricant.
- Seaside where the air contains much salt.
- Hot spring area where corrosive gases exist, e.g., sulfide gas.
- Factories where the supply voltage fluctuates seriously.
- Inside a car or cabin.
- Place like kitchen where oil permeates.
- Place where strong electromagnetic waves exist.
- Place where flammable gases or materials exist.
- Place where acid or alkali gases evaporate.
- Other special environments.

Precautions before installation

- Decide the correct way of conveying the equipment.
- Try to transport this equipment with the original package.
- If the air conditioner needs to be installed on a metal part of the building, electric insulation must be performed, and the installation must meet the relevant technical standards of electric devices.
- Before installing the unit, be sure to confirm with the user whether there are wires, water pipes, air pipes and so on in the wall or ground of the installation site to avoid accidents due to damage.

7.2 Installing the fan coil units

Confirm the dimensions of the fan coil unit(s) against the following figure.

- Install $\Phi 10$ pendant bolts (4 bolts)
- The intervals of the pendant bolts are shown in the following figure.
- Use the $\Phi 10$ pendant bolts.
- The treatment of the ceiling varies between buildings. For detailed measures, negotiate with the construction and fit-out staff.
 - Scope of dismantling the ceiling.
 - Please keep the ceiling horizontal.
 - Reinforce the beams and girders of the ceiling lest vibration of the ceiling.

Cut off the beams and girders of the ceiling.

Reinforce the cut-off part, beams and girders of the ceiling.

- After the main body is suspended, work on the pipes and wires in the ceiling. Decide the lead-out direction of the pipes after selecting the installation site. Especially, in a circumstance where a ceiling is available, extend the refrigerant pipe, drain pipe, indoor/outdoor connection wires and wire controller lines to the connection position before suspending the unit.

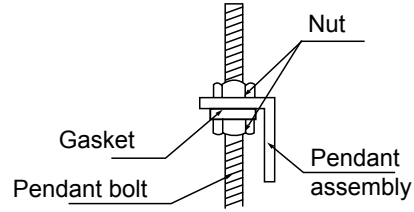

Fig.7-4

7.2.1 Procedure of installing the pendant bolts

- Base on the unit structure, please set the screw-pitch according to the size of the following figures:

Wooden structure

Put rectangular sticks across the beams, and set pendant bolts.

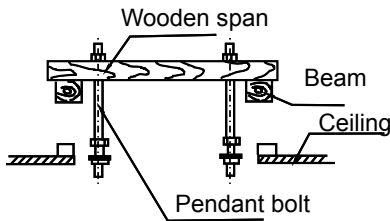

Fig.7-1

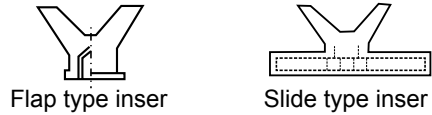

Fig.7-5

Old concrete roughcast

Use embedded bolts and embedded pulling plugs.

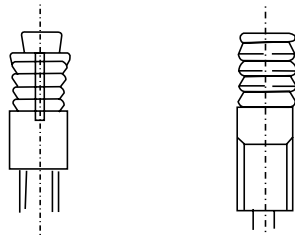

Fig.7-2

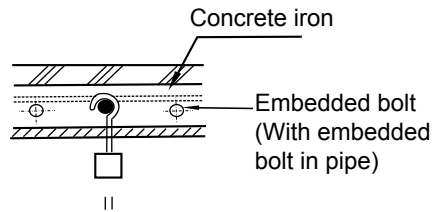

Fig.7-6

Steel beam and girder structure

Set and use supportive angle steel.

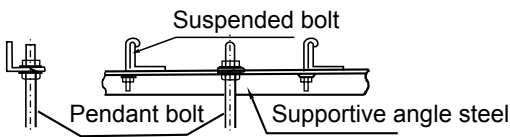

Fig.7-3

- Suspending the fan coil unit(s)
Use tools such as pulleys to hoist the fan coil unit(s) to the pendant bolt.
- Connect the duct
The duct length is determined according to the external static pressure.
- Install the wire control switch
For installation of the wire control switch, see the installation manual of the wire controller.

7.2.2 Space requirement

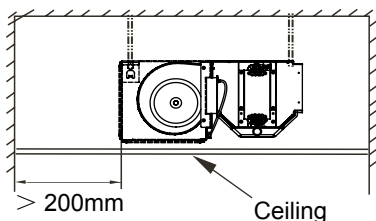

Fig.7-7

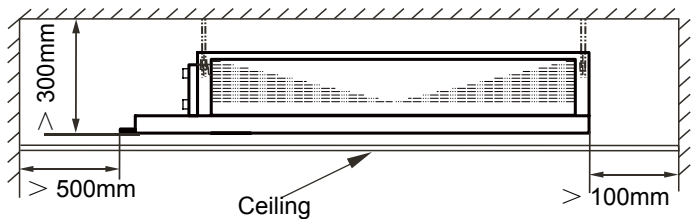

Fig.7-8

7.2.3 Dimensions

Two-pipe:

The quantities of the fans and motors are only for references, please prevail in kind!

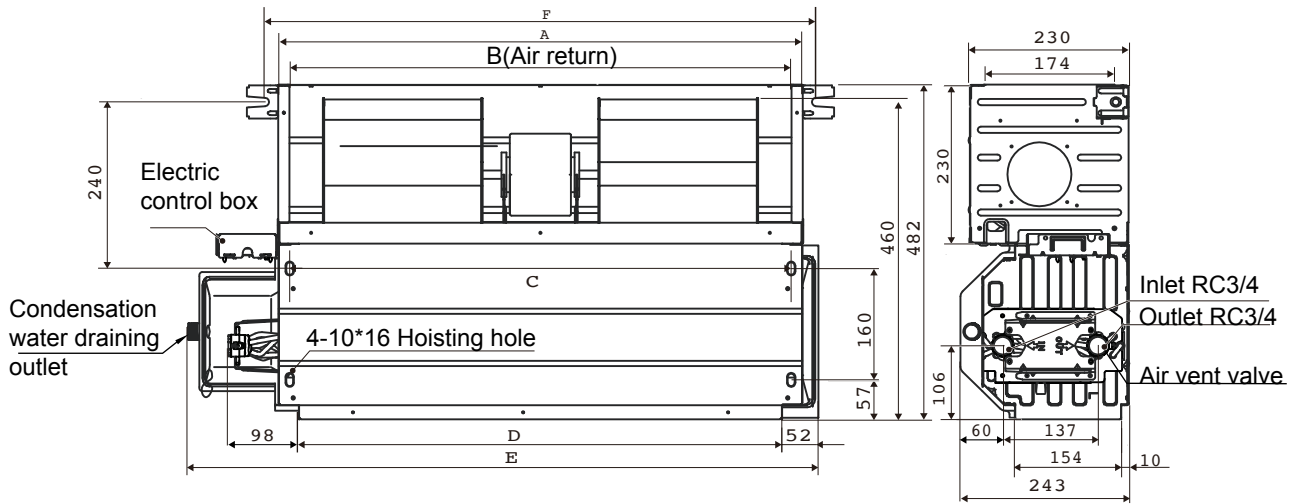

Fig..7-9.1

Table 7-1

Model Size	200 Model	300 Model	400 Model 500 Model	600 Model	700 Model	800 Model 1000 Model	1200 Model	1400 Model
A	475	620	755	850	1025	1215	1505	1745
B	443	588	723	818	993	1183	1473	1713
C	442	587	722	817	992	1182	1472	1712
D	415	560	695	790	965	1155	1445	1685
E	632	773	908	1003	1178	1368	1658	1898
F	513	658	793	888	1063	1253	1543	1783

Four-pipe:

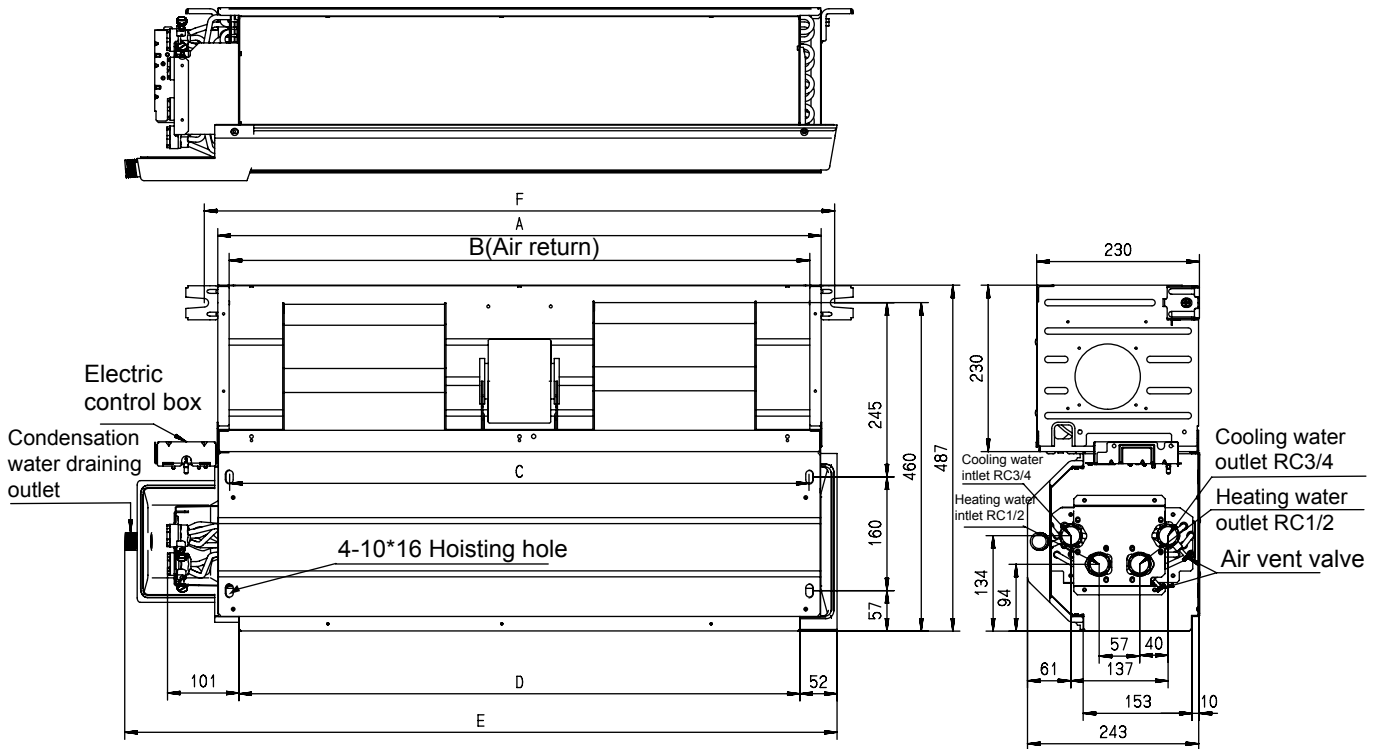

Fig..7-9.2

Table 7-2

Size \ Model	200 Model	300 Model	400 Model 500 Model	600 Model	700 Model	800 Model 1000 Model	1200 Model	1400 Model
A	475	620	755	850	1025	1215	1505	1745
B	443	588	723	818	993	1183	1473	1713
C	442	587	722	817	992	1182	1472	1712
D	415	560	695	790	965	1155	1445	1685
E	632	773	908	1003	1178	1368	1658	1898
F	513	658	793	888	1063	1253	1543	1783

NOTE

- The above figures is an instance models, which would be different from the one that you purchase.
- If the configuration of the model you choose is an extended water pan, the total length E will be 200 more than the values in the table above.
- The external filter of the fan coil configuration is different, which may lead to different dimensions of the unit, such as purificator plate series, large temperature difference wind disc series, etc., for details, please refer to the manual or consult the manufacturer.

7.3 Connect the accessional plastic water tray (without air return box)

- The grooves of the accessional plastic water tray can be locked at the brim of the main water tray.

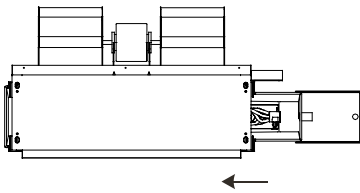

Fig.7-10



Fig.7-11

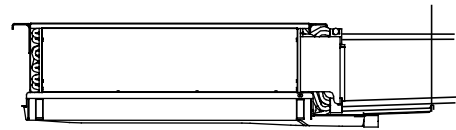
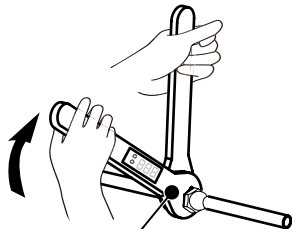

Fig.7-12

- Please hang up the accessional plastic water tray to the pipes or ceiling by a rope.

8 PIPES CONNECTION

- With air release valve, the other side is water inlet pipe. When connect water collector, set the tightening torque to 61.8-75.4 N·m (6.3-7.7 kgf·m), and use a spanner to tighten it as shown in Figure.
- The diameter of connective junction in water inlet pipe and water outlet pipe is RC3/4 taper pipe thread inside.
- Air conditioning end devices such as fan coils should be equipped with electric control valves in the return pipes.
- The diameter of condensate pipe is ZG3/4 taper pipe thread outside.



Torque wrench

Fig. 8-1

NOTE

- The downward gradient of the drain pipe should be higher than (1/100), without bend in the middle.
- The total length of the drain pipe when pulled out transversely shall not exceed 20m, when the pipe is over long, a prop stand must be installed prevent winging.
- The centralized pipes should be distributed against the figure shown on the right side.

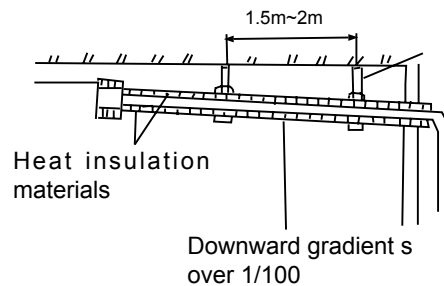

Fig 9-1

9 INSTALLING DRAINAGE PIPE

- Install the drain pipe of the fan coil unit. Before out from factory, the scupper adopts the pipe thread.

NOTE

- Be sure to perform heat insulation for the drain pipe of the fan coil unit(s). Otherwise, condensate will occur. The joint of the fan coil unit(s) should also undergo heat insulation treatment.
- When performing the pipes connection, use the rigid PVC binder, and make sure that no leak exists.
- Same as the joint of the fan coil unit(s). Be careful not to apply force at the pipe side of the fan coil unit(s).

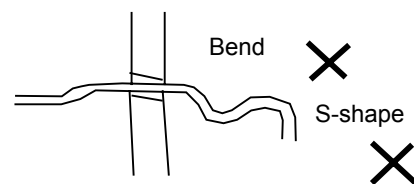

Fig 9-2

As large as practicable (approx. 10cm)

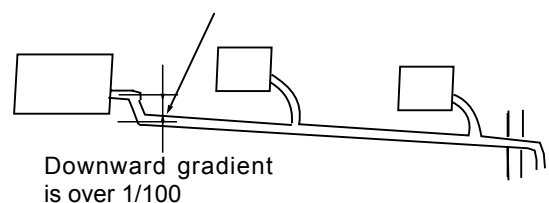

Fig 9-3

Drain test

Before the test, ensure that the drain pipes are smooth and the adapters are sealed.

Newly built rooms should undergo the drain test before the ceiling is laid.

10 WIRING

 **CAUTION**

- The air conditioner should use separate power supply with rated voltage.
- The external power supply to the air conditioner should have ground wiring, which is linked to the ground wiring of the fan coil unit and outdoor unit.
- The wiring work should be done by qualified persons according to circuit drawing.
- an all-pole disconnection device which has at least 3 mm separation distance in all pole and a residual current device(RCD) with the rating of above 10mA shall be incorporated in the fixed wiring according to the national rule.
- The appliance shall be installed in accordance with national wiring regulations.
- Be sure to locate the power wiring and the signal wiring well to avoid cross-disturbance.
- Do not turn on the power until you have checked carefully after wiring.

Table 10-1

AIR FLOW (cfm)		200 cfm to 1400 cfm
POWER	PHASE	1-phase
	FREQUENCY AND VOLT	220-240 V~ 50 Hz
CIRCUIT BREAKER/FUSE(A)		15/15
INDOOR POWER WIRING (mm ²)	NO ELECTRIC AUXILIARY HEATING	3 * 1.5
	WITH ELECTRIC AUXILIARY HEATING	3 * 2.5

The power cord type designation is H05RN-F or above.



16126200001125 V.C

frigicoll

OFICINA CENTRAL
Blasco de Garay, 4-6
08960 Sant Just Desvern
Barcelona
Tel. 93 480 33 22
<http://www.frigicoll.es>

BUREAU CENTRAL
Parc Silic-Immeuble Panama
45 rue de Villeneu
94150 Rungis
Tél. +33 9 80 80 15 14
<http://www.frigicoll.es>