

Wall-mounted S8

PRODUCT SHEET



KI-05

Recommended controller

Product certified by:



FEATURES

Model	KAYF-15 DN5.0	KAYF-22 DN5.0	KAYF-28 DN5.0
Rated cooling capacity	1,50 kW	2,20 kW	2,80 kW
Rated heating capacity	1,70 kW	2,40 kW	3,20 kW
Consumption	18 W	21 W	24 W
Power supply	220-240/1/50	220-240/1/50	220-240/1/50
MCA: Minimum circuit amps	0,28 A	0,29 A	0,36 A
MFA: Max. fuse amps	15 A	15 A	15 A
Air flow rate	340/360/380/400/420/440/460 m ³ /h	340/370/390/410/440/470/500 m ³ /h	340/370/400/430/470/510/540 m ³ /h
Sound pressure	27/28/29/30/31/32 dB(A)	27/28/29/30/31/32 dB(A)	28/30/31/32/33/34/35 dB(A)
Liquid pipe diameter	6,35 mm	6,35 mm	6,35 mm
Gas pipe diameter	12,7 mm	12,7 mm	12,7 mm

WIRING DIAGRAM

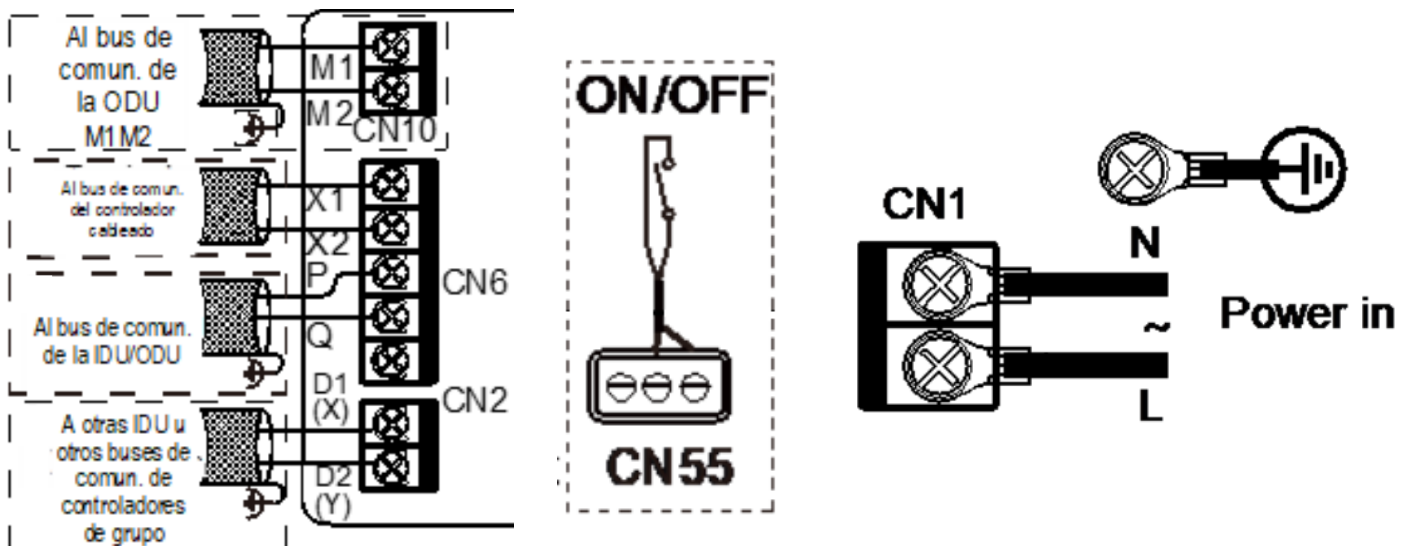

NOTES:

- (1) The data and specifications present in this sheet may vary without notice.
- (2) The images on this sheet are indicative and may be different from the final machine.

DIMENSIONS & WEIGHT

	KAYF-15 DN5.0	KAYF-22 DN5.0	KAYF-28 DN5.0
A	750 mm	750 mm	750 mm
B	295 mm	295 mm	295 mm
C	265 mm	265 mm	265 mm
D	581 mm	581 mm	581 mm
E	736 mm	736 mm	736 mm
Inner unit weight	9 kg	9 kg	10 kg

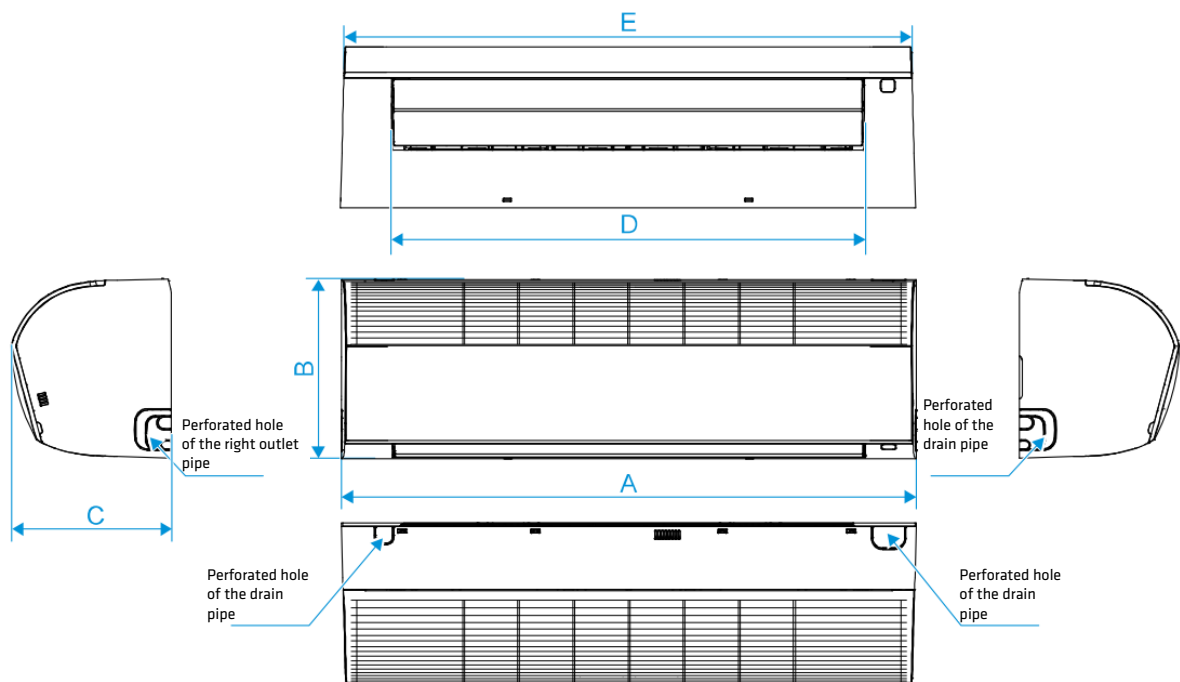

INSTALLATION

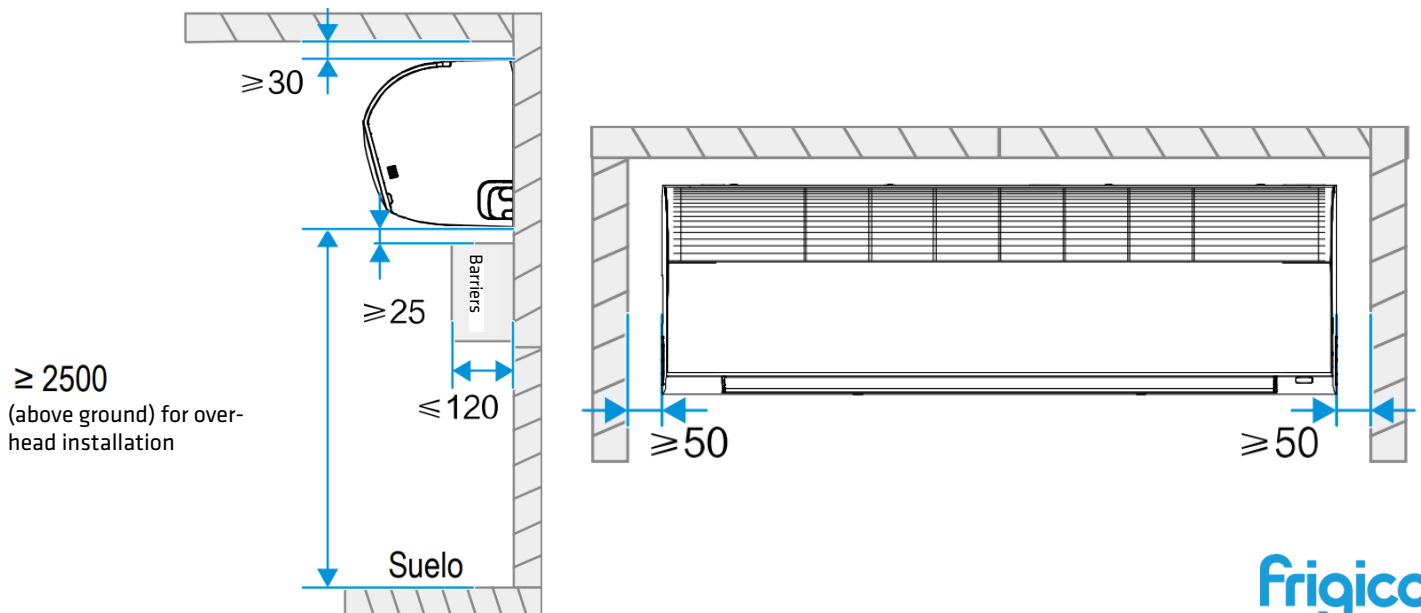

Wall-mounted S8

PRODUCT SHEET



KI-05

Recommended controller

Product certified by:



FEATURES

Model	KAYF-36 DN5.0	KAYF-45 DN5.0	KAYF-56 DN5.0
Rated cooling capacity	3,60 kW	4,50 kW	5,60 kW
Rated heating capacity	4,00 kW	5,00 kW	6,30 kW
Consumption	27 W	30 W	40 W
Power supply	220-240/1/50	220-240/1/50	220-240/1/50
MCA: Minimum circuit amps	0,39 A	0,41 A	0,51 A
MFA: Max. fuse amps	15 A	15 A	15 A
Air flow rate	340/380/420/460/500/540/580 m ³ /h	410/460/510/560/620/670/720 m ³ /h	410/480/550/620/700/780/860 m ³ /h
Sound pressure	28/30/31/33/34/36/37 dB(A)	29/30/31/32/33/35/37 dB(A)	29/31/33/35/37/39/41 dB(A)
Liquid pipe diameter	6,35 mm	6,35 mm	6,35 mm
Gas pipe diameter	12,7 mm	12,7 mm	12,7 mm

WIRING DIAGRAM

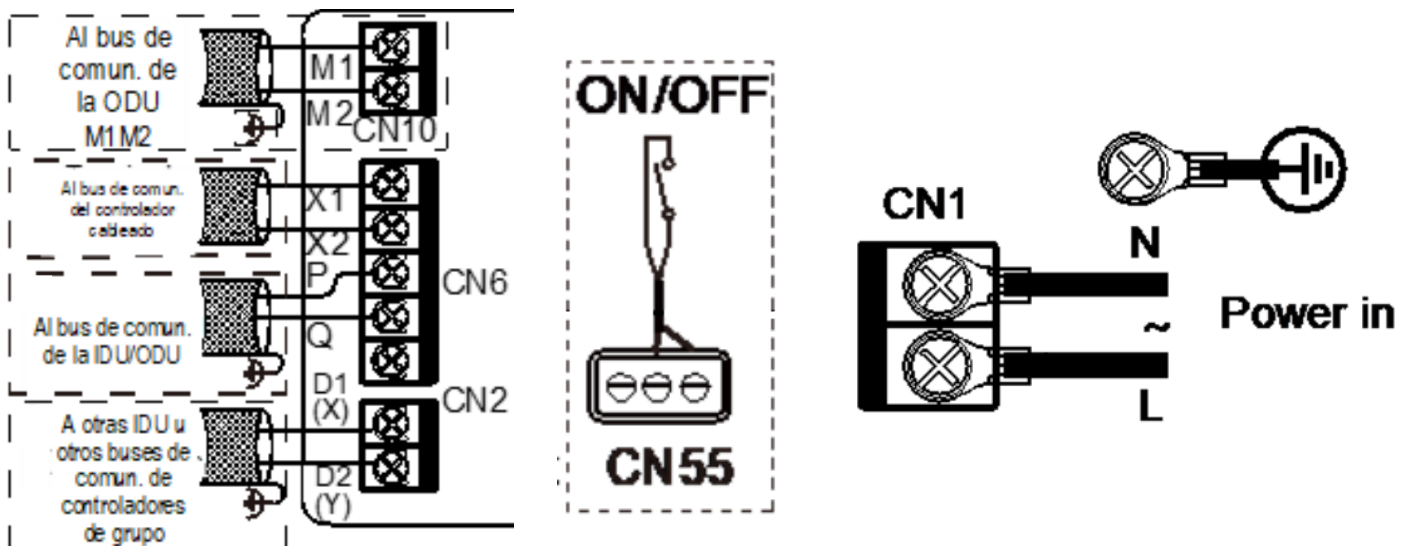

NOTES:

- (1) The data and specifications present in this sheet may vary without notice.
- (2) The images on this sheet are indicative and may be different from the final machine.

DIMENSIONS & WEIGHT

	KAYF-36 DN5.0	KAYF-45 DN5.0	KAYF-56 DN5.0
A	750 mm	950 mm	950 mm
B	295 mm	295 mm	295 mm
C	265 mm	265 mm	265 mm
D	581 mm	781 mm	781 mm
E	736 mm	936 mm	936 mm
Inner unit weight	10 kg	11,5 kg	11,5 kg

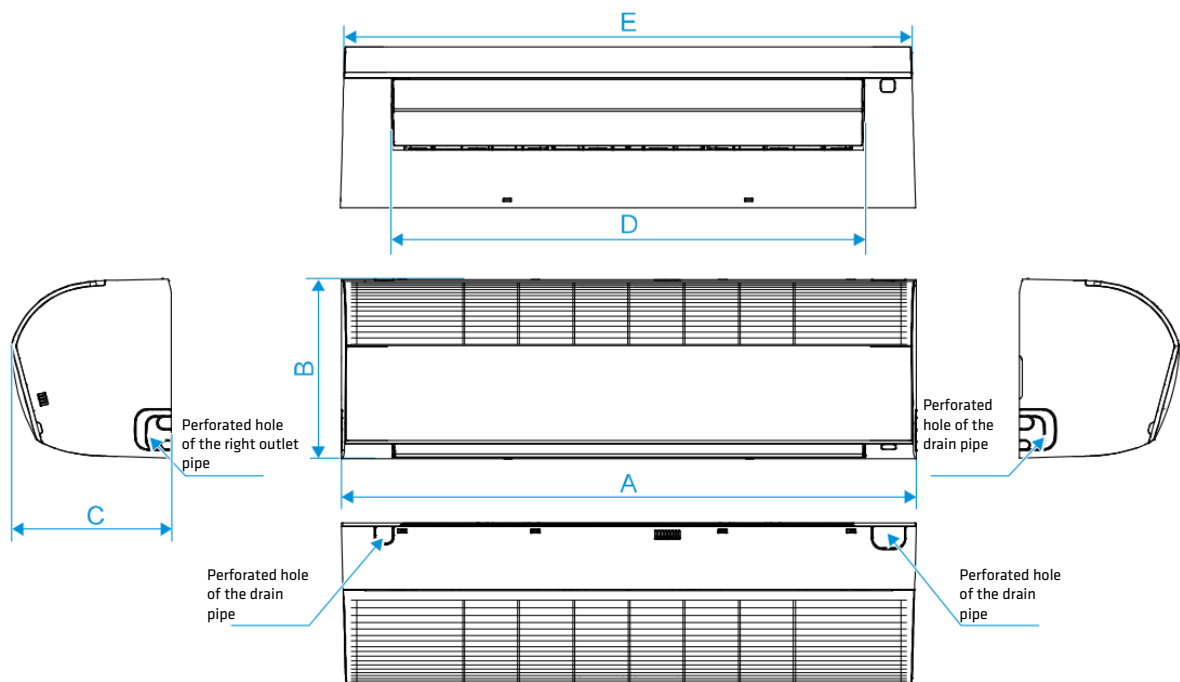

INSTALLATION

