

Onnix 2.0

Multisystem

PRODUCT SHEET



KID-05.4 S
Standard controller

Product certified by: 



FEATURES

Model	KAY-D 26 DR10	KAY-D 35 DR10	KAY-D 52 DR10
Cooling capacity	2,63	3,52	5,28
Heating capacity	2,93	3,81	5,57
Airflow	700 / 515 / 425	700 / 515 / 425	750 / 530 / 430
Sound pressure	40 / 32.5 / 21.5	40 / 32.5 / 21.5	41.5 / 36.5 / 33.5 / 19
Power supply	220-240 V / 1 / 50 Hz		
Communication wiring	(3+T) x 2,50 mm ²	(3+T) x 2,50 mm ²	(3+T) x 2,50 mm ²
Refrigerating pipes	Ø1/4" / Ø3/8"	Ø1/4" / Ø3/8"	Ø1/4" / Ø1/2"

WIRING DIAGRAM

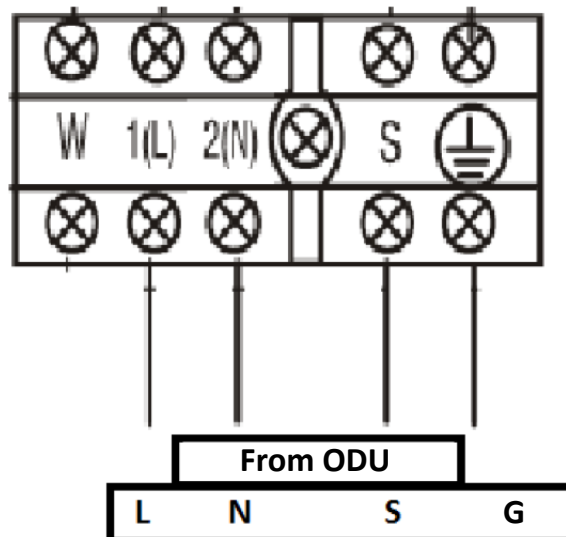

NOTES:
 (1) The data and specifications present in this sheet may vary without notice.
 (2) The images on this sheet are indicative and may be different from the final machine.

DIMENSIONS & WEIGHT OF INDOOR UNIT

Model	Weight	W	H	D
KAY-D 26 DR10	11,30 kg	920 mm	211 mm	321 mm
KAY-D 35 DR10	11,30 kg	920 mm	211 mm	321 mm
KAY-D 52 DR10	11,30 kg	920 mm	211 mm	321 mm

