

# Modular Full DC Inverter Heat Pump

## PRODUCT SHEET



**KCCHT-06 MODBUS**  
Standard control with  
Modbus protocol gateway.  
Included as standard

Product certified by:



## FEATURES

Model	KEM-HT-65 DR55	KEM-HT-110 DR55
Cooling capacity	57 kW	100 kW
Cooling power input	19.000 W	32.800 W
Heating capacity	65 kW	110 kW
Heating power input	18.300 W	29.900 W
EER / COP	3,00 / 3,55	3,05 / 3,68
SEER	4,40	4,60
SCOP (average zone water 35 °C) - Energy class	4,40 - A+++	4,60 - A++
Compressor type / No. compressors	EVI Scroll Inverter / 1	EVI Scroll Inverter / 2
No. fans	2	2
Air flow	22.000 m <sup>3</sup> /h	32.500 m <sup>3</sup> /h
Sound pressure	64 dB(A)	64 dB(A)
Refrigerant / supplementary charge	9 kg / - kg	11,5 kg / 4,0 kg
Water flow	9,8 m <sup>3</sup> /h	17,2 m <sup>3</sup> /h
Hydraulic connections	2"	2 1/2"
Power supply	380-415 V / 3 / 50 Hz	380-415 V / 3 / 50 Hz

## OPERATING LIMITS

Cooling mode

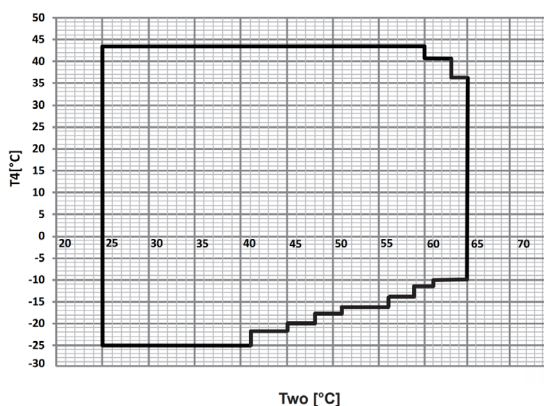

Heating mode

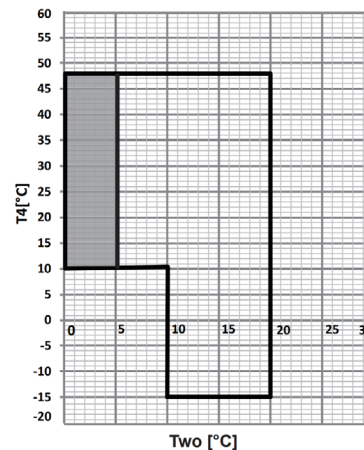

NOTES:

(1) The data and specifications present in this sheet may vary without notice.

(2) The images on this sheet are indicative and may be different from the final machine.

# INSTALLATION COMPONENTS

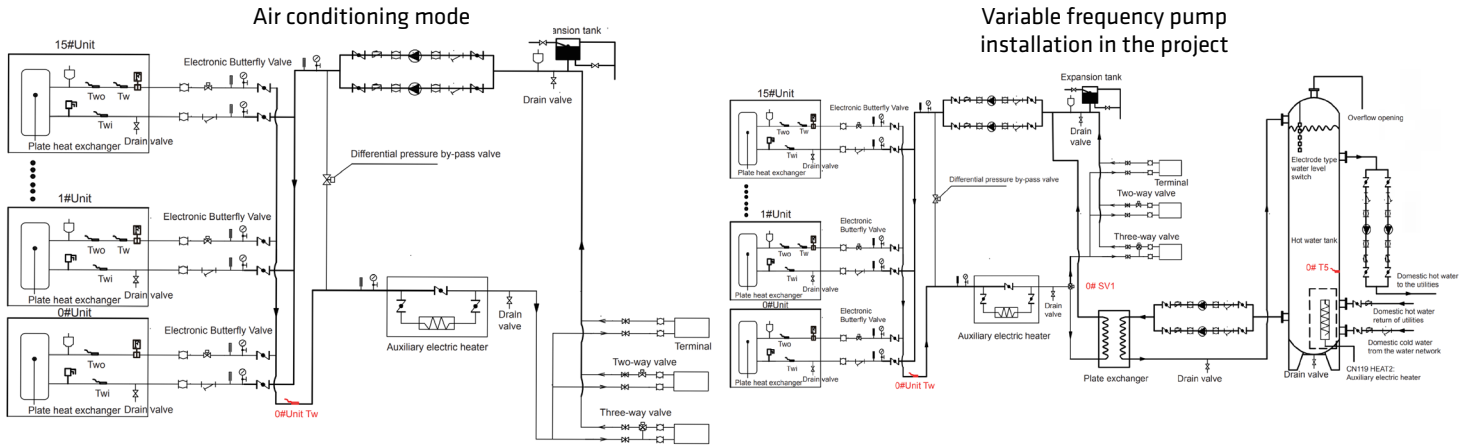

# WIRING DIAGRAM

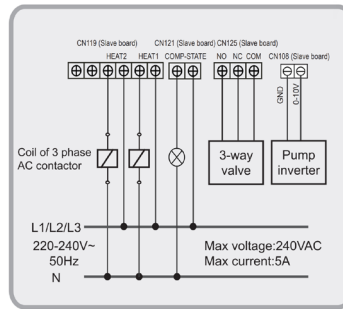

# DIMENSIONS OF UNIT

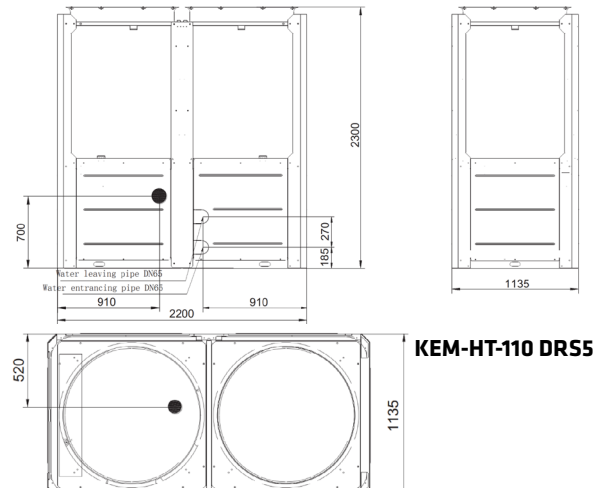
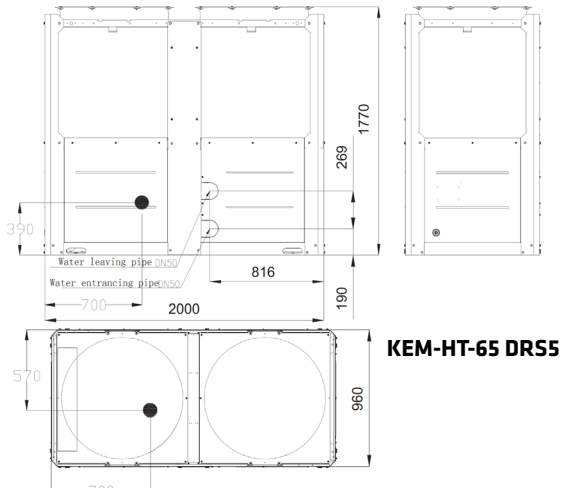

# INSTALLATION

