

Double Flow Console Multisystem

PRODUCT SHEET



KID-05 S
Recommended controller



FEATURES

Model	KSD-35 DR14	KSD-52 DR14
Cooling capacity	3,52 kW	5 kW
Heating capacity	3,81 kW	4,98 kW
Airflow	420/520/620 m ³ /h	510/620/670 m ³ /h
Sound pressure	33,50/38/41,50 dB(A)	36/39/45 dB(A)
Power supply	220-240 V / 1 / 50 Hz	
Communication wiring	(3+T)x2,50 mm ²	(3+T)x2,50 mm ²
Refrigerating pipes	Ø1/4" / Ø3/8"	Ø1/4" / Ø1/2"

WIRING DIAGRAM

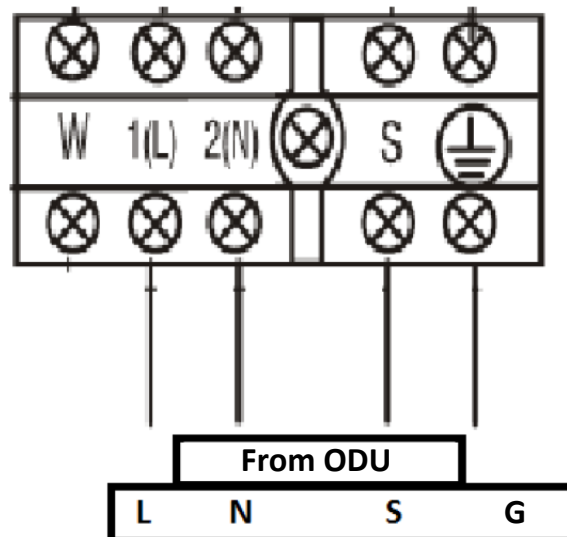

DIMENSIONS & WEIGHT OF INDOOR UNIT

Model	Weight	Width	Height	Depth
KSD-32 DR14	10,50 kg	793 mm	621 mm	200 mm
KSD-52 DR14	10,50 kg	793 mm	621 mm	200 mm

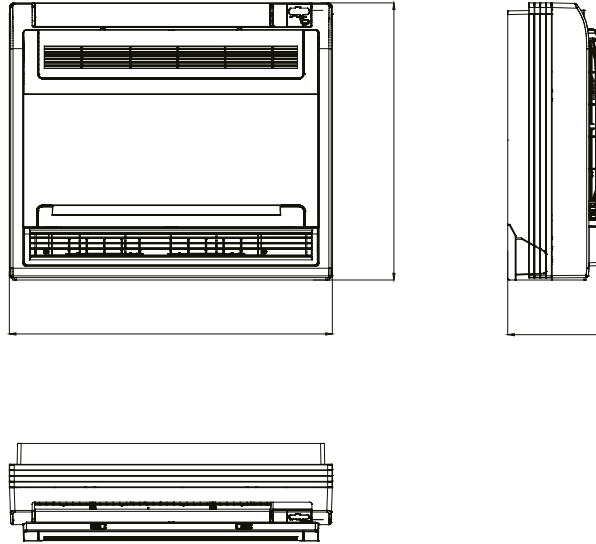

INSTALLATION

