

Double Flow Console

PRODUCT SHEET

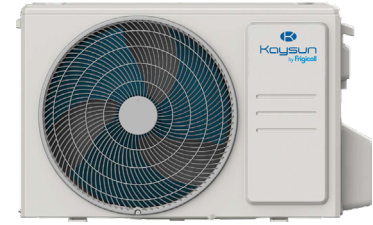

KID-05 S
Recommended controller



FEATURES

Model	KSDA-35 DVR14
Cooling capacity	3,52 kW
Cooling power input	1.020 W
Heating capacity	3,81 kW
Heating power input	1.090 W
ErP Classification cold/heat	A++ / A+
Airflow (indoor)	420/520/620 m ³ /h
Sound pressure (indoor)	33,50/38/41,50 dB(A)
Airflow (outdoor)	2.200 m ³ /h
Sound pressure (outdoor)	53,60 dB(A)
Power supply	220-240 V / 1 / 50 Hz
Max. input	9 A
Power wiring (outdoor)	(2+T)x1,50 mm ²
Communication wiring	(3+T)x1 mm ²

WIRING DIAGRAM

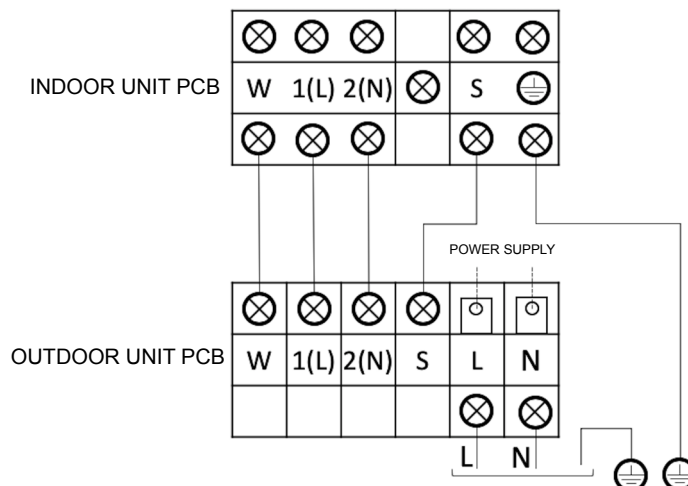

NOTES:

- (1) The data and specifications present in this sheet may vary without notice.
 (2) The images on this sheet are indicative and may be different from the final machine.

COOLING CONNECTION

Model	KSDA-35 DVR14	
Refrigerating pipes	Ø1/4" / Ø3/8"	
Refrigerant charge / Additional charge	0,72 kg / 0,012 kg	
Indoor drain pipe	Ø16	
Max. pipe length (A)	25 m	
Max. level difference (B)	10 m	

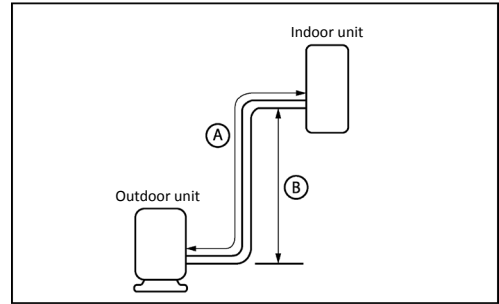

DIMENSIONS & WEIGHT INDOOR

Model	KSD-35 DR14
Width	793 mm
Height	621 mm
Depth	200 mm
Weight	14,60 kg

DIMENSIONS & WEIGHT OUTDOOR

Model	KUE-35 DVR13
Width	765 mm
Height	555 mm
Depth	303 mm
Weight	26,60 kg

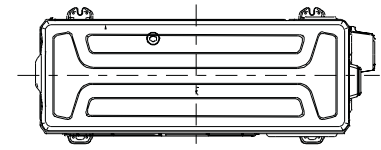
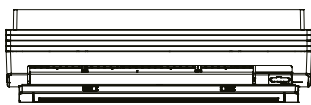
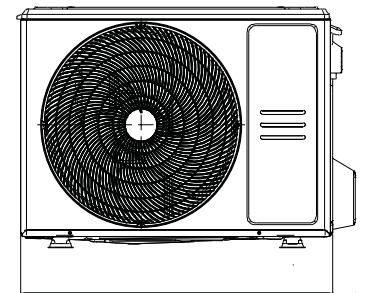
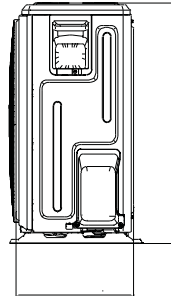
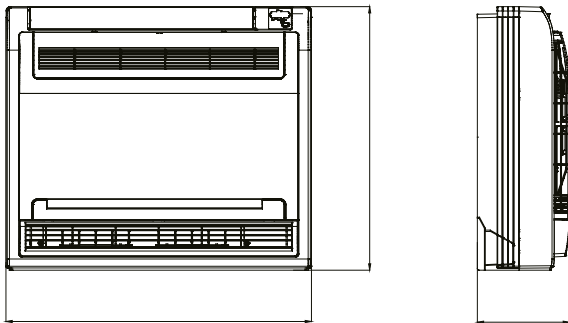

INSTALLATION

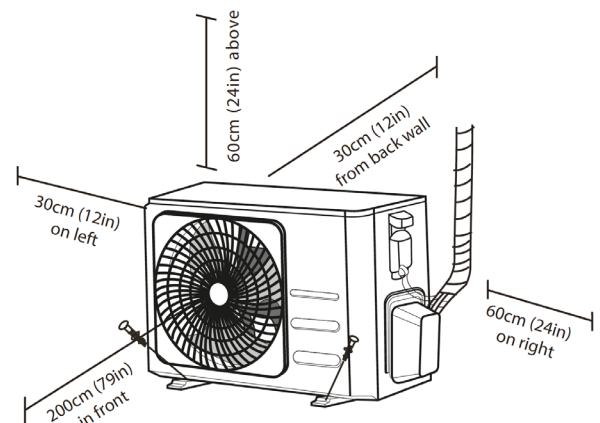
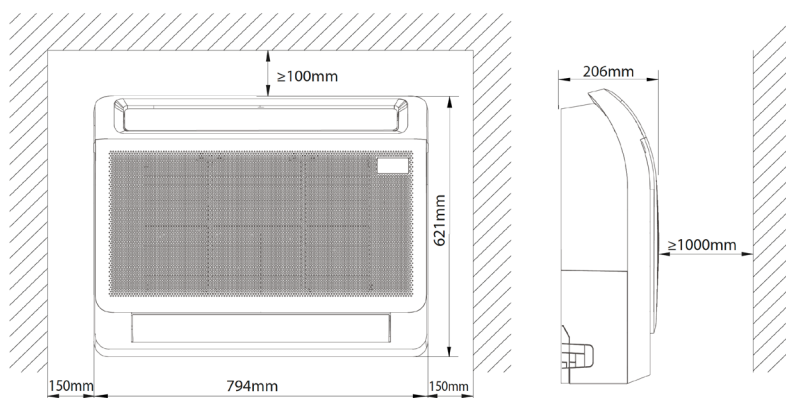

Double Flow Console

PRODUCT SHEET



KID-05 S
Recommended controller

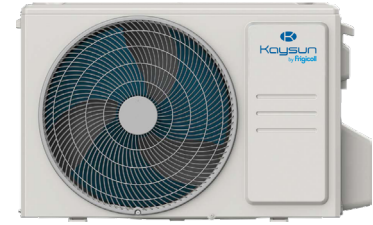

FEATURES

Model	KSDA-52 DVR14
Cooling capacity	5 kW
Cooling power input	1.600 W
Heating capacity	4,98 kW
Heating power input	1.548 W
ErP Classification cold/heat	A++ / A+
Airflow (indoor)	510/620/670 m ³ /h
Sound pressure (indoor)	36/39/45 dB(A)
Airflow (outdoor)	2.100 m ³ /h
Sound pressure (outdoor)	56 dB(A)
Power supply	220-240 V / 1 / 50 Hz
Max. input	13,50 A
Power wiring (outdoor)	(2+T)x1,50 mm ²
Communication wiring	(3+T)x1 mm ²

WIRING DIAGRAM

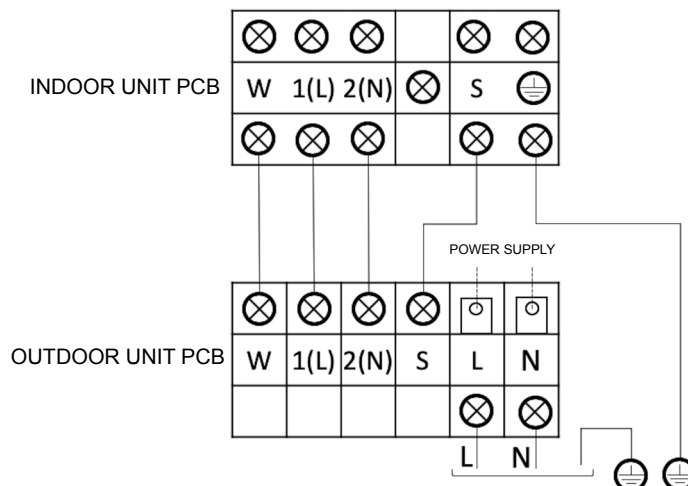

NOTES:
 (1) The data and specifications present in this sheet may vary without notice.
 (2) The images on this sheet are indicative and may be different from the final machine.

COOLING CONNECTION

Model	KSDA-52 DVR14	
Refrigerating pipes	Ø1/4" / Ø1/2"	
Refrigerant charge / Additional charge	1,15 kg / 0,012 kg	
Indoor drain pipe	Ø16	
Max. pipe length (A)	30 m	
Max. level difference (B)	20 m	

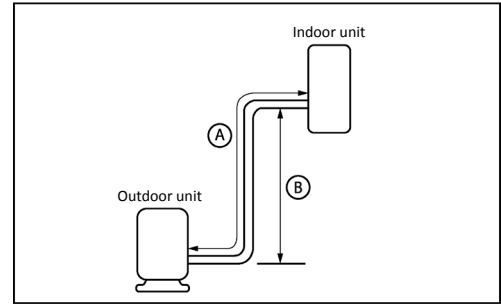

DIMENSIONS & WEIGHT INDOOR

Model	KSD-52 DR14
Width	793 mm
Height	621 mm
Depth	200 mm
Weight	14,70 kg

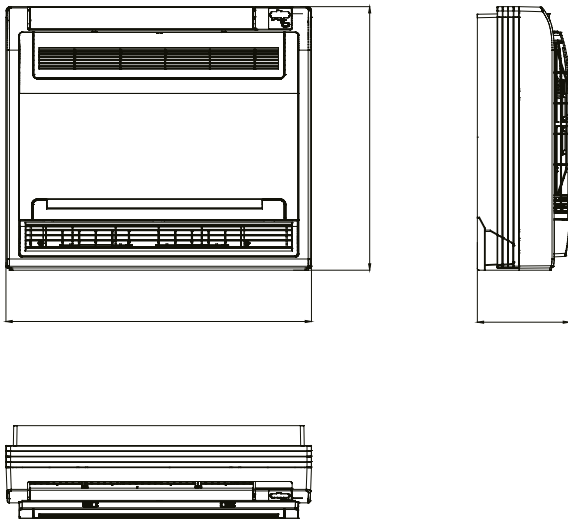

DIMENSIONS & WEIGHT OUTDOOR

Model	KUE-52 DVR13
Width	805 mm
Height	554 mm
Depth	330 mm
Weight	32,50 kg

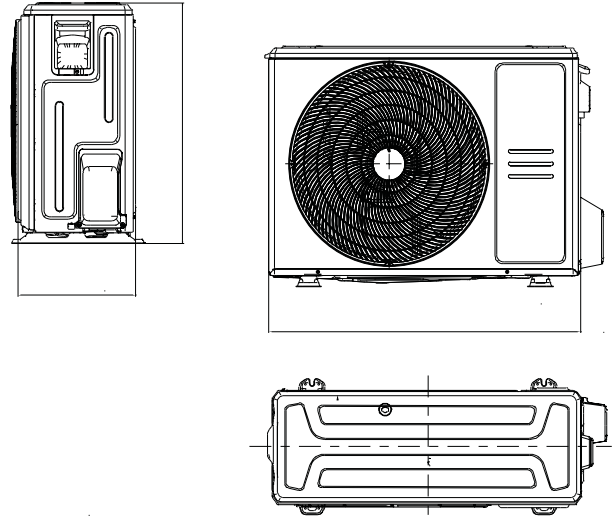

INSTALLATION

