

ORIGINAL  
MANUAL

# frigicoll

## OWNER'S AND INSTALLATION MANUAL

---

Compact distribution module

KIRE2HX

KIRE2HLX



Read this manual carefully before using the product, and keep it handy for future reference.

### SECTION 1: INTRODUCTION AND GENERAL INSTRUCTIONS

- Description
- Packing list
- General instructions and safety rules

### SECTION 2: TECHNICAL DATA

- DN25 manifolds technical data
- Distribution modules technical data

### SECTION 3: DIMENSIONS AND CONNECTIONS

### SECTION 4: EXAMPLE OF APPLICATIONS

### SECTION 5: INSTALLATION

- Safety thermostat and pump electric connection
- Insert placing

## SECTION 1: GENERAL INSTRUCTIONS AND SAFETY RULES

### DESCRIPTION

This module suitable for 2 zone heating systems.

The zones are served by 2 types of circulation units.

- Direct unit "D" (high temperature), Modulating temperature mixing unit "TS". For this unit is available an heating controller.  
The zone manifold/hydraulic separator is provided with a threaded cap for the separation/connection of the flow/return chambers.

### PACKING LIST

- No. 1 insulated box for installation on wall, complete of zone manifold/hydraulic separator, wall bracket and anti-rotation jig.
- No.1 Module assembling instructions
- No. 2 distribution groups
- No. 1 temperature probe T1B / Tw2

### GENERAL INSTRUCTIONS AND SAFETY RULES

**Consult this manual carefully before proceeding with any intervention on the equipment.**

The manufacturer, in order to adapt to technological and equipment needs of the productive character or installation, may, without notice, make modifications to it. Therefore, although the illustrations in this manual can differ slightly from the equipment in your possession, safety is the same guaranteed. This manual is part of the product and should be adequately stored so that it could be consulted during the lifetime of the equipment. Keep the instructions with the product if you are transferring to another owner.

#### **Preliminary checks**

Before each operation carefully remove the packaging and check the integrity of the equipment. If you note some defects or damages do not install it or attempt to repair the equipment, but contact your dealer.

#### **Installation**

All operations on the product must be made with power disconnected from the mains.

Installation should be done in accordance with the laws and regulations of each country.

Producer responsibility is limited to providing the equipment. Its installation should be made in conformity with the rules of art, according to the requirements of these instructions and the rules of their profession by qualified staff, acting under suitable companies to take full responsibility of the whole plant.

**Frigicoll. is not responsible for the product modified without permission, and for the replacements of no-original components.**

#### **Electrical connection**

The controller must be installed and connected by authorized staff according to applicable regulations.

Connect the power supply to the control unit complete with bipolar switch fuses (power 230Vac 50Hz). It is essential to connect the proper grounding



The controller must be connected into the network as the current regulations demands. The proper functioning of the controller is guaranteed only for the provided pump.

#### **Hydraulic connections**

After delivery of the product, ensure the tightening of all nuts fixing the pipes.

**Be especially careful when you are connecting the piping kit to the hydraulic module, and avoid to bend the copper pipes.**



Installation, connections and testing must be done by qualified staff who works in accordance with the standards and follows the instruction manual. All piping should be insulated in accordance with the law.

#### **Please follow these tips:**

- Do not touch hot parts of the module such as pipe inlet and outlet of water. Every contact with them can cause dangerous burning.
- Do not expose the unit to spray water and other liquids.
- Do not place anything on the unit.
- Do not expose the unit to vapors from a cooking surface.
- Prohibit the use of the equipment for children and inexperienced people.
- Do not touch the appliance with wet or damp parts of the body and / or bare feet.
- Do not pull the wires.

## SECTION 2: TECHNICAL DATA - DN25 MANIFOLD

### DN25

#### COMPONENTS:

- 1 Manifold / separator black painted (DN25 2 zone manifold);
- 2 Black EPP insulation (front and back);
- 3 Threaded cap with watertight cap;
- 4 Anti-rotation jig;
- 5 Wall bracket

#### TECHNICAL DATA

Max. working temperature	110°C
DN20 manifold max flow	3.000 l/h
Max. working pressure	6 bar
Zone manifold material	Acciaio ST37.1
Insulation material	EPP 60 g/l
Zone manifold painting	RAL 9004

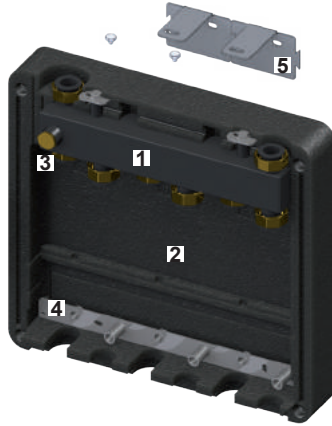

#### DN25 MANIFOLD PRESSURE LOSS

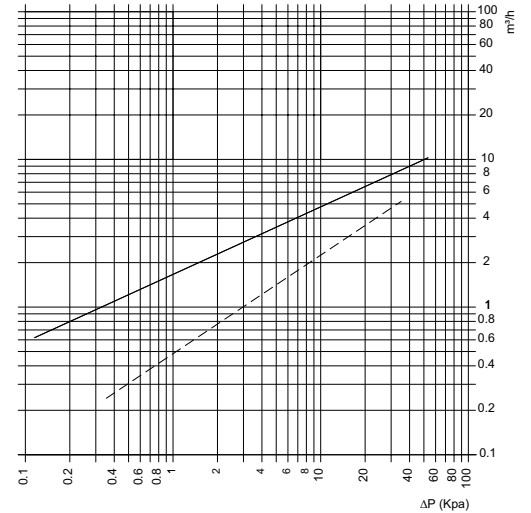

### MIXED

- 1 Pump type Wilo YONOS PARA RS 25/1-6 180;
- 2 Modulating temperature mixing valve DN25;
- 3 Piping kit;
- 4 Return check valve;
- 5 Ball valve with handle and thermometer;
- 6 Accessory: electric servomotor 230 V o 24 V.

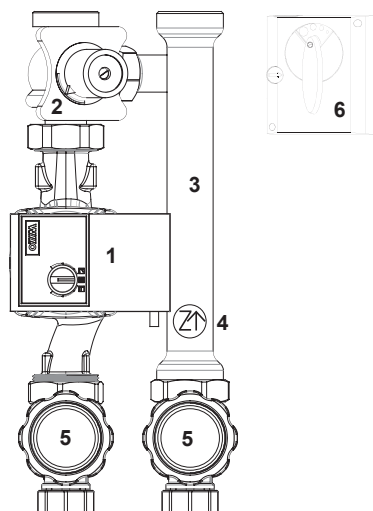

### PRESSURE LOSS / PUMP CHARACTERISTICS

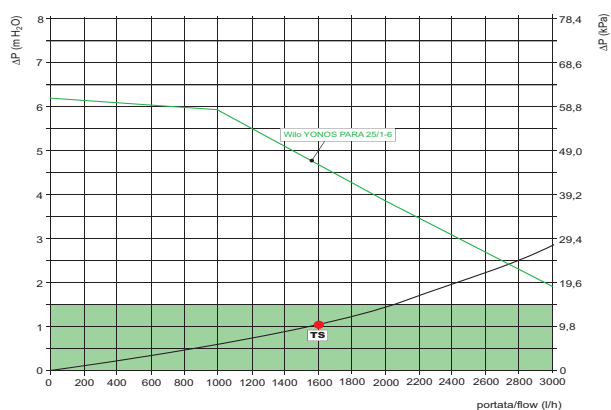

### TECHNICAL DATA

Max. working temperature	110°C
Max. working pressure	6 bar
Max flow rate. (ΔP 10 KPa)	1.600 l/h
Max heating power (ΔT 20)	37,2 kW
Circulation unit material	OT58 / Cu
Supply voltage of pump	230 V - 50 Hz



For further informations about the pumps please read the Wilo manuals into the packaging

### HIGH TEMPERATURE

- 1 Pump type Wilo YONOS PARA RS 25/1-6 180;
- 2 Piping kit;
- 3 Return check valve;
- 4 Ball valve with handle and thermometer;

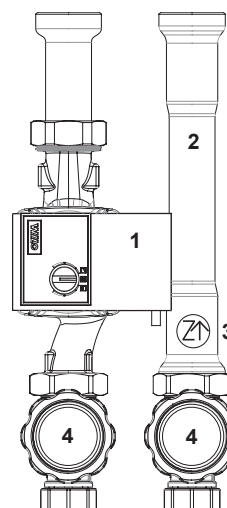

### PRESSURE LOSS / PUMP CHARACTERISTICS

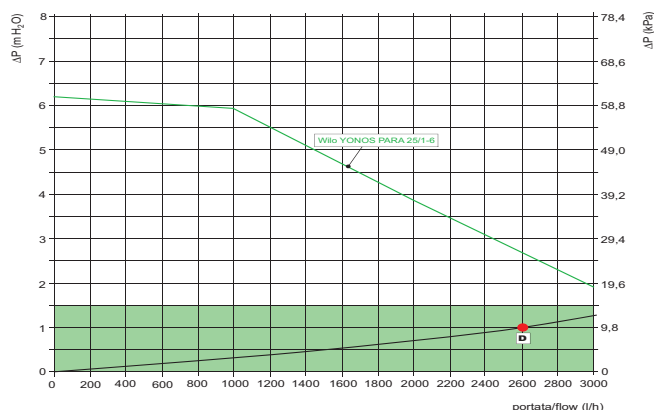

### TECHNICAL DATA

Max. working temperature	110°C
Max. working pressure	6 bar
Max flow rate. (ΔP 10 KPa)	2.600 l/h
Max heating power (ΔT 20)	60,5 kW
Circulation unit material	OT58 / Cu
Supply voltage of pump	230 V - 50 Hz



For further informations about the pumps please read the Wilo manuals into the packaging

SEZIONE 3: DIMENSIONS AND CONNECTIONS

RELAY FORM DN25

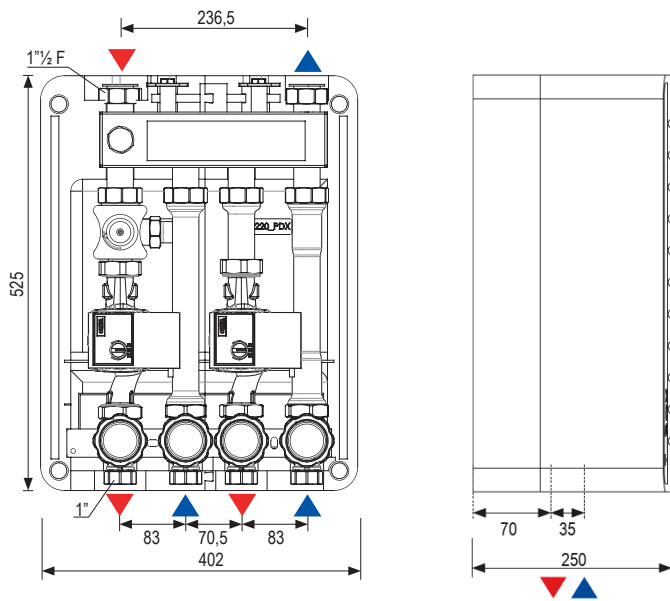

SECTION 4: EXAMPLE OF APPLICATION

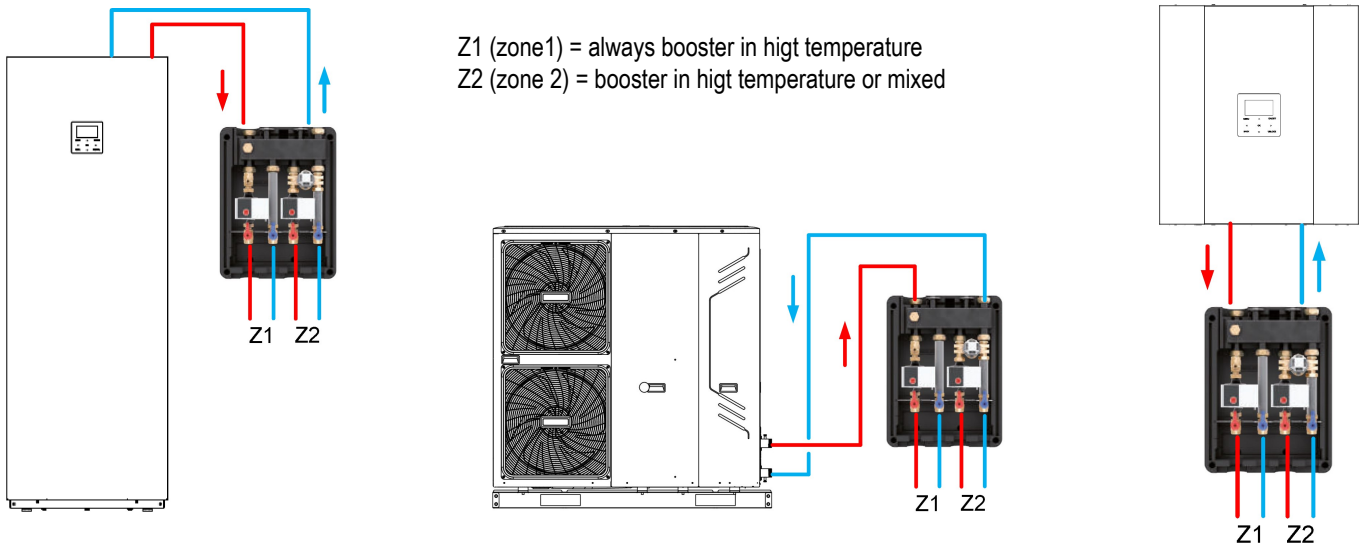

Z1 (zone1) = always booster in high temperature  
 Z2 (zone 2) = booster in high temperature or mixed

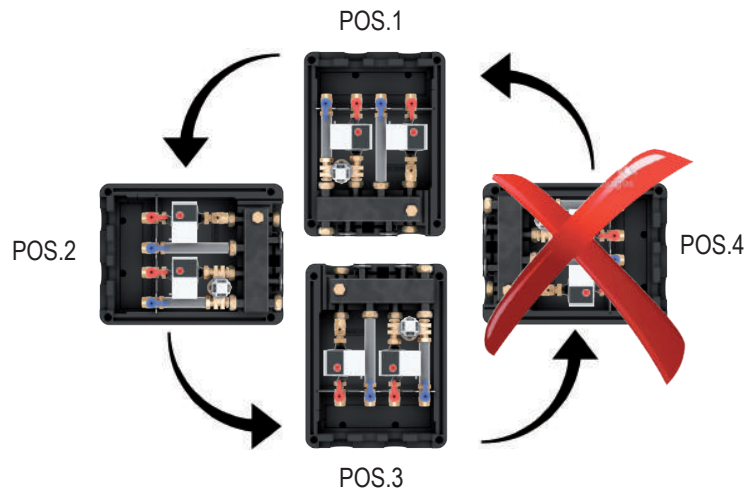

## SECTION 5: INSTALLATION

### PRELIMINARY CHECK

Before every operation carefully remove the packaging and verify if there is external damages. In case of damages please do not install the products. Dispose the packaging parts in compliance with the local regulations.



The product is supplied by the manufacturer completely screwed. The transport or a long stock may not grant the seal. Please check the seal before the filling of the system



All the operation must be done with power supply disconnected to the electricity grid



The installation must be done in compliance with the local regulations



The responsibility of the manufacturer shall be limited to the products. The installation must be carried out by qualified personnel

### ASSEMBLING AND COMMISSIONING



The module is designed for the distribution of the water into the heating/cooling systems.



The installation, setting and maintenance of the appliance must be performed by professionally trained and qualified personnel, with the professional prerequisites.



The place of the installation must be dry and the ambient temperature must not exceed 40°C.



Connect the pipes of the system respecting the connection as indicated in the section 3.



Handling with care!



**ATTENTION!**  
HANDLE WITH CARE!

1. Carefully remove the module taking care not to damage it, remove the frontal insulation lifting up with both hands. Attention: the frontal insulation is divided in different parts. Remove it entirely.

2. Through a wrench unscrew and remove the screws as shown in the picture below then remove the wall bracket as shown in the picture 2a.

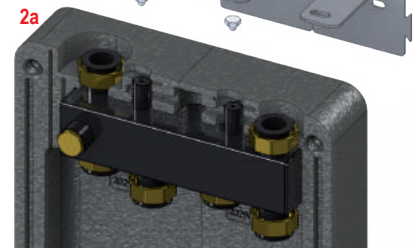
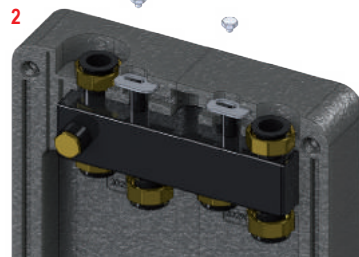

**ATTENTION!**  
PLACE THE BRACKET IN THE  
CORRECT PLACE



3. Place the drilling jig on the wall in the position you would install the modul  
After having fixed the drilling jig, drill the wall in correspondence of the right holes as shown in the picture on the left, then remove the drilling jig and fix the wall brackets on the wall through the 12 mm anchor screw (not included). Picture 3a

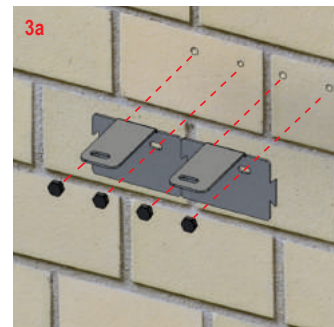

# Assembling instructions and maintenance

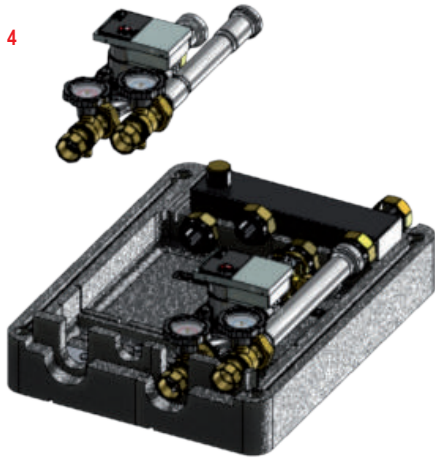

4. Before fixing the zone manifold/hydraulic separator to the wall install the distribution units to it .  
As shown in the picture 4a and 4b pay attention when fixing the units to the anti-rotation jig.



**ATTENTION!**  
SCREW THE NUTS  
WATERTIGHT



Circulation unit fixing DN25

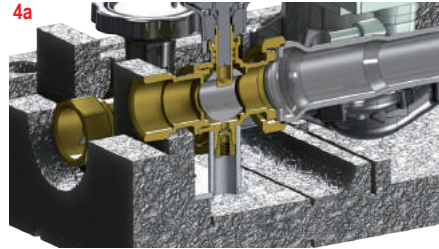

Circulation unit fixing DN20

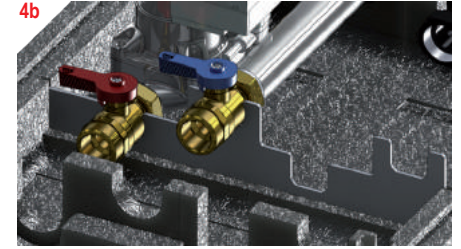

5. Fix the modul on the wall using the wall brackets previously installed. Screw the hex head screws

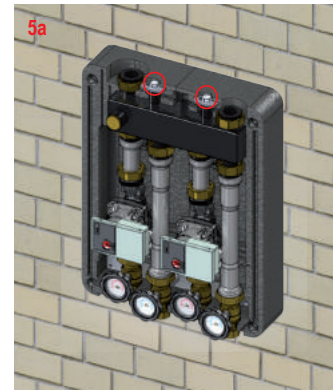
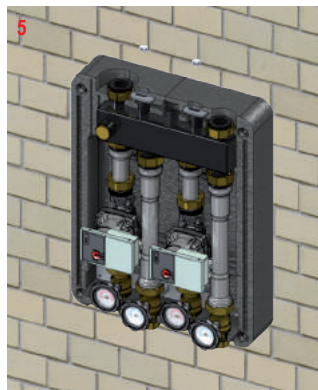

POSITION OF THE THREADED CAP of the zone manifold.

6. Change the position of the threaded cap before filling the system.  
If the system is in pressure, close the ball valves on the distribution units and the ball valves upstream of the zone manifold.

## CONNECTING CHAMBERS:

The connection between flow and return chambers allows the management of a system with several interacting circulators.

### STANDARD SUPPLIED.

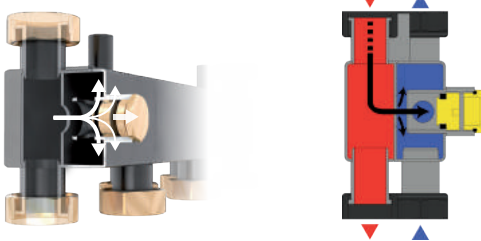

## SEPARATE CHAMBERS:

Screw to stroke end the cap.

Further to what described at the point 6, unscrew the watertight cap and through a screwdriver screw to stroke and the threaded cap (picture 6a).

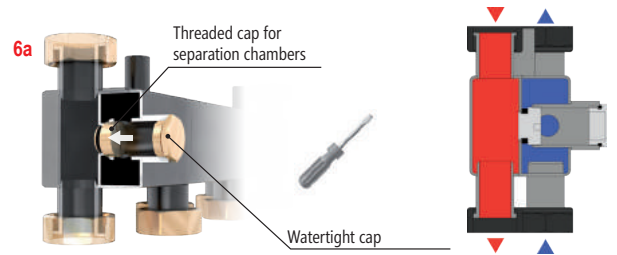

7. Assembling the mixing unit "TS" (DDN25):  
Unscrew the socket head screw as shown in the picture 7 and remove the handle

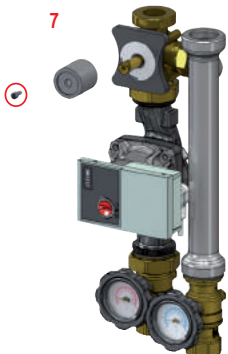

**ATTENTION!**

Before removing the black handle make sure that the arrows is in correspondence of the position 10 as shown in the picture 7a (total recirculation).  
Put the actuator in manual operation.  
Rotate the handle in correspondence to the blue symbol (valve completely closed).

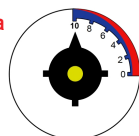

Fix the anti-rotation screw in a hole of the valve's flange (picture 7b), then install the electric actuator.

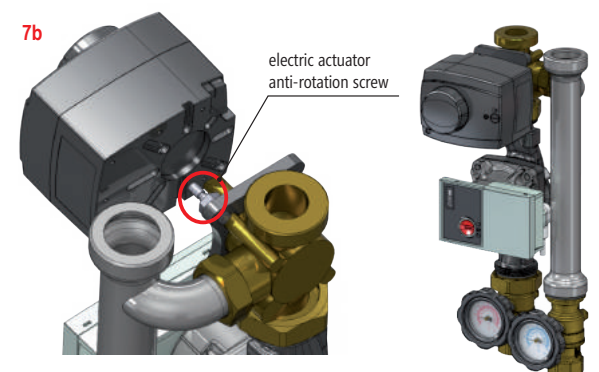

## Assembling instructions and maintenance

Position the T1B / Tw2 temperature probe (contained with in the kit) T1BX (supplied separately for Edge), in the delivery pipe of the low temperature zone (fig. **7c**) using the pipe clamps. It is advisable to isolate the probe in order to read the temperature better.

A= T1B / Tw2 / T1BX temperature probe  
B= Delivery pipe

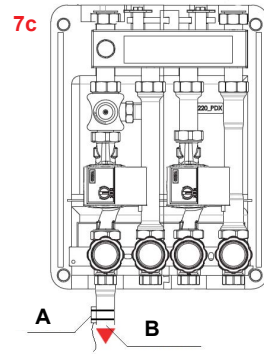

PLACE THE EPP INSERT TO THE FRONTAL INSULATION:  
follow the instructions.

**9b**



Relay modul DN25 insert placing:  
Coupling the inserts (2 or 3 in function of the T-Box model)  
as shown in the picture **9b**

N.B. THE INSERT HAVE TO BE COUPLED TO THE  
FRONTAL INSULATION AND NOT DIRECTLY TOTHE PUMP

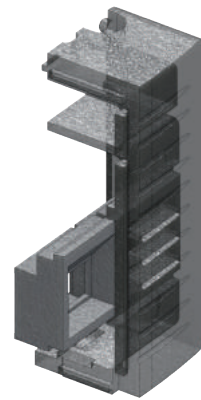

**HOW TO ENABLE THE 2 ZONES OPTION**

Go on MENU> FOR SERVICEMAN> 5. TEMP. TYPE SETTING. Click OK.

The following page will be displayed:

5 TEMP. TYPE SETTING	
5.1 WATER FLOW TEMP.	<b>YES</b>
5.2 ROOM TEMP.	NON
5.3 DOUBLE ZONE	NON
↕ ADJUST	↔

Select YES also on item 5.3 DOUBLE ZONE by moving with the arrows.

5 TEMP. TYPE SETTING	
5.1 WATER FLOW TEMP.	YES
5.2 ROOM TEMP.	NON
5.3 DOUBLE ZONE	<b>YES</b>
↕ ADJUST	↔





*\* The 5.2 ROOM TEMP. option It is not selectable*

Set the parameter: 15.3 CN15 T1B > YES

See manual in section 9 Start-up: Menu > for serviceman > input define

**To check the correct selection of 2-zone mode:**

Return to the Homepage, move to the right with the arrow until you see the screen of the second zone

01-01-2018 23:59 13°		01-01-2018 23:59 13°	
	ON		 2
23 °C		38 °C	

Homepage (zone 1)

Addition page (zone 2)

Sequence	Content
T1B / TW2 / T1BX	Outlet water temperature of Zone 2
SV3	Mixing valve (field supply)
KM6	Ac Contactor Outside Circulator Pump or Zone 1 Pump
KM7	Ac Contactor Zone 2 Pump

### Thermostats connection

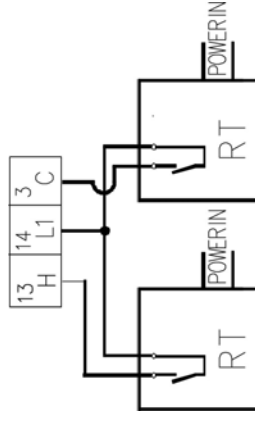

Zone 1: high temperature between H and L1

Zone 2: low temperature between C and L1

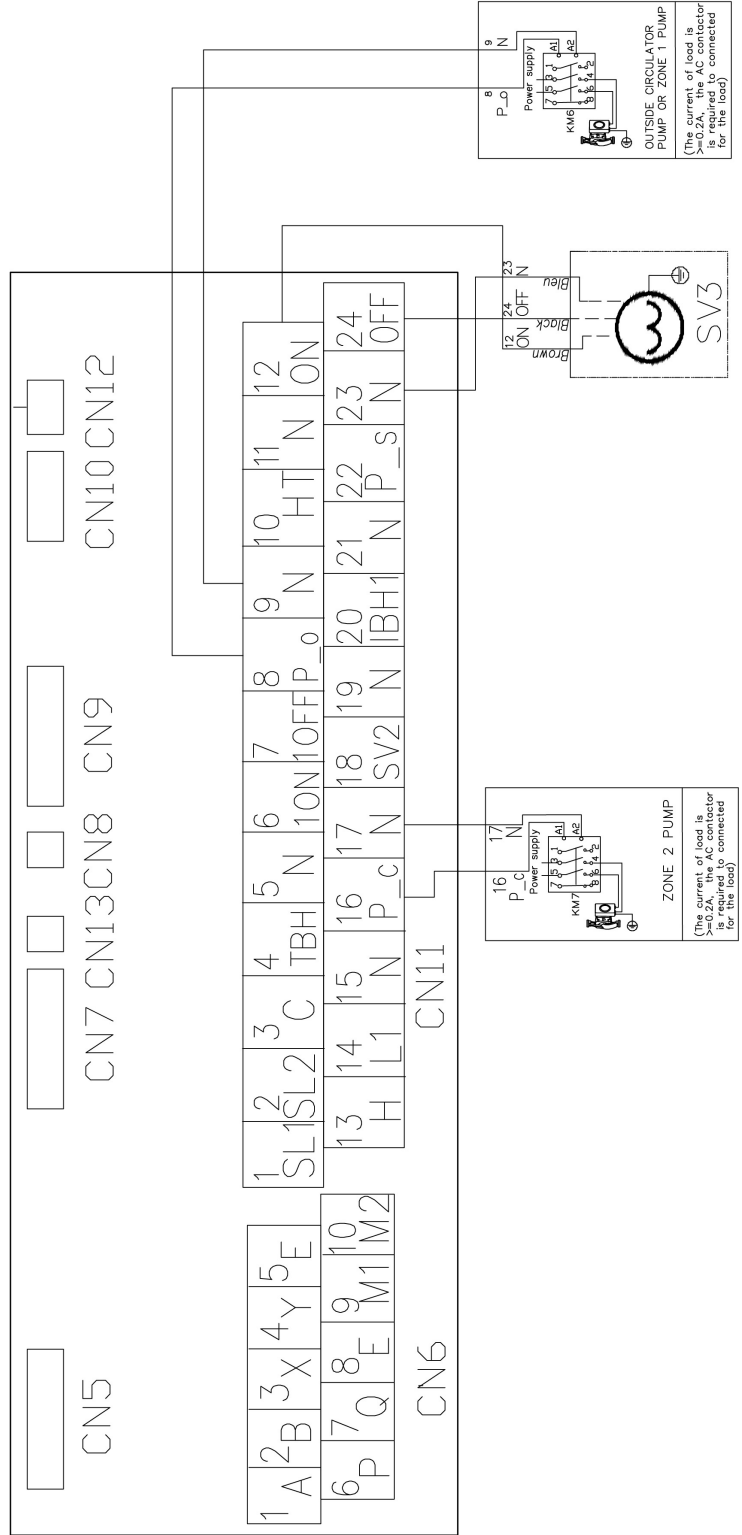
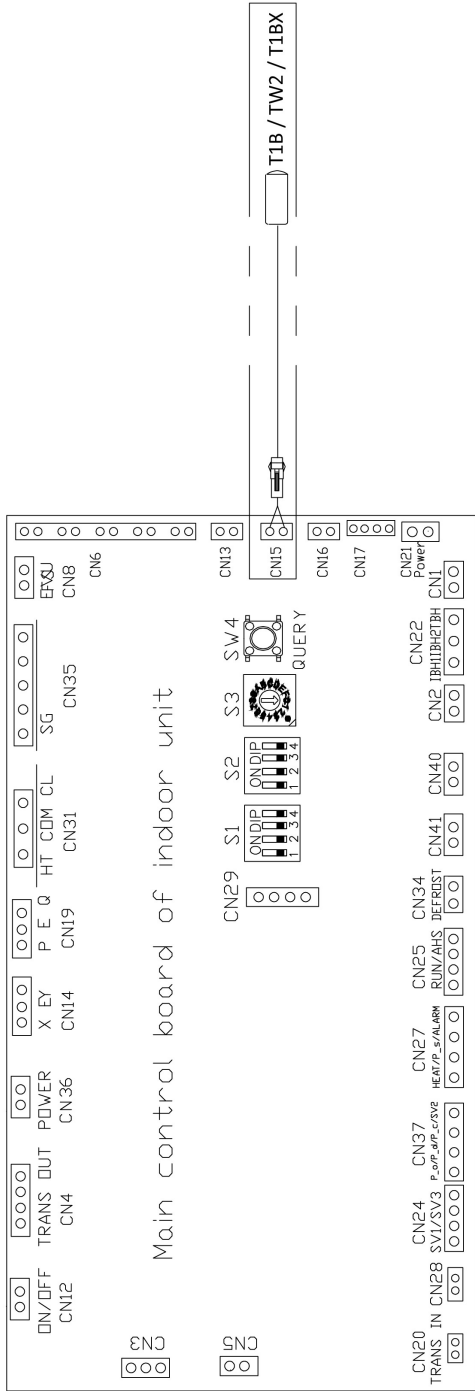

# frigicoll

OFICINA CENTRAL  
Blasco de Garay, 4-6  
08960 Sant Just Desvern  
Barcelona  
Tel. 93 480 33 22  
<http://www.frigicoll.es>

BUREAU CENTRAL  
Parc Silic-Immeuble Panama  
45 rue de Villeneu  
94150 Rungis  
Tél. +33 9 80 80 15 14  
<http://www.frigicoll.es>