

# Casual Multisystem

## PRODUCT SHEET



KID-05.3 S  
Standard controller

Product certified by: **CE**



### FEATURES

Model	KAY-CF 20 DR11	KAY-CF 26 DR11	KAY-CF 35 DR11	KAY-CF 52 DR11	KAY-CF 71 DR11
Cooling capacity	2,05 kW	2,64 kW	3,52 kW	5,28 kW	7,03 kW
Heating capacity	2,64 kW	2,93 kW	3,81 kW	5,57 kW	7,33 kW
Airflow	434/333/259 m <sup>3</sup> /h	434/333/259 m <sup>3</sup> /h	314/430/540 m <sup>3</sup> /h	540/680/840 m <sup>3</sup> /h	662/817/980 m <sup>3</sup> /h
Sound pressure	21 dB(A)	21 dB(A)	21 dB(A)	20 dB(A)	36 dB(A)
Power supply	220-240 V / 1 / 50 Hz				
Communication wiring	(3+T)x2,50 mm <sup>2</sup>				
Refrigerating pipes	Ø1/4" / Ø3/8"	Ø1/4" / Ø3/8"	Ø1/4" / Ø3/8"	Ø1/4" / Ø1/2"	Ø3/8" / Ø5/8"

### WIRING DIAGRAM

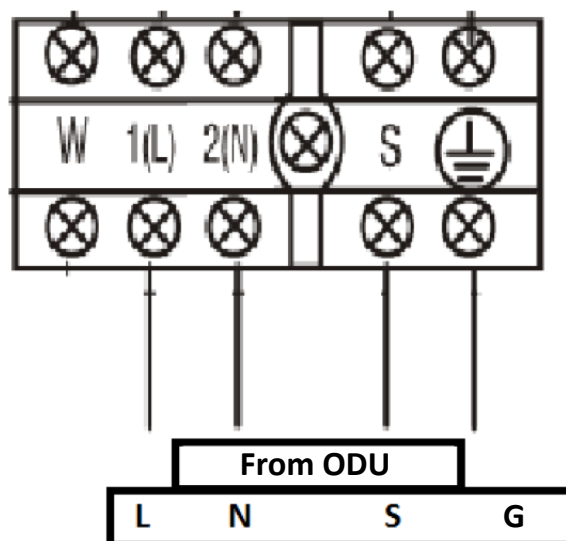

NOTES:  
(1) The data and specifications present in this sheet may vary without notice.  
(2) The images on this sheet are indicative and may be different from the final machine.

## DIMENSIONS & WEIGHT OF INDOOR UNIT

Model	Weight	A	B	C
KAY-CF 20 DR11	7 kg	715 mm	285 mm	194 mm
KAY-CF 26 DR11.1	7,60 kg	715 mm	285 mm	194 mm
KAY-CF 35 DR11	7,60 kg	805 mm	285 mm	194 mm
KAY-CF 52 DR11	10 kg	957 mm	302 mm	213 mm
KAY-CF 71 DR11	12,30 kg	1.040 mm	327 mm	220 mm

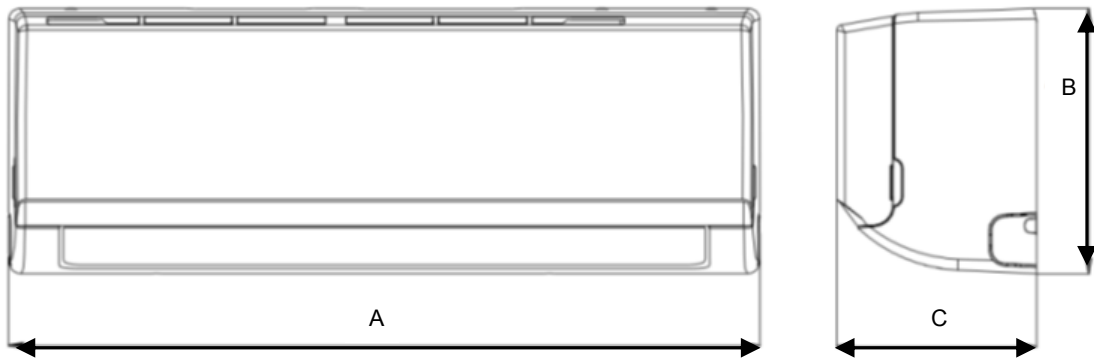

## INSTALLATION

