

ORIGINAL  
MANUAL



# INSTALLATION & OWNER'S MANUAL

KRE (Heat Recovery Ventilation)

KRE-500D1

KRE-1500D1

KRE-1000D1

KRE-2000D1



Thank you very much for purchasing our air conditioner.  
Before using your air conditioner, please read this manual carefully and keep it for future reference.

## WARNING

If the supply cord is damaged, it must be replaced by the manufacturer or its service agent or a similarly qualified person in order to avoid a hazard.

An all-pole disconnection device which has at least 3mm separation distance in all pole and a residual current device(RCD)with the rating of above 10mA shall be incorporated in the fixed wiring according to the national rule.

Disconnect the power supply before cleaning and maintenance.

The appliance shall be installed in accordance with national wiring regulations.

This appliance can be used by children aged from 8 years and above and persons with reduced physical, sensory or mental capabilities or lack of experience and knowledge if they have been given supervision or instruction concerning use of the appliance in a safe way and understand the hazards involved.

Children shall not play with the appliance.

Cleaning and user maintenance shall not be made by children without supervision. DISPOSAL: Do not dispose this product as unsorted municipal waste.

Collection of such waste separately for special treatment is necessary.

Directive 2002/96/EC (WEEE):

The symbol depicting a crossed-out waste bin that is underneath the appliance indicates that this product, at the end of its useful life, must be handled separately from domestic waste, must be taken to a recycling centre for electric and electronic devices or handed back to the dealer when purchasing an equivalent appliance



# MAIN PARTS OF THE UNIT

KRE-500D1~KRE-1000D1

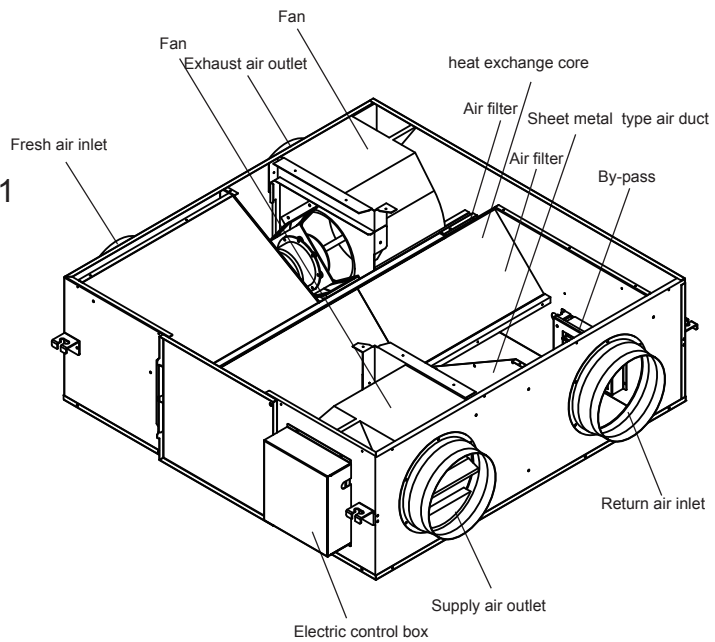

KRE-1500D1~KRE-2000D1

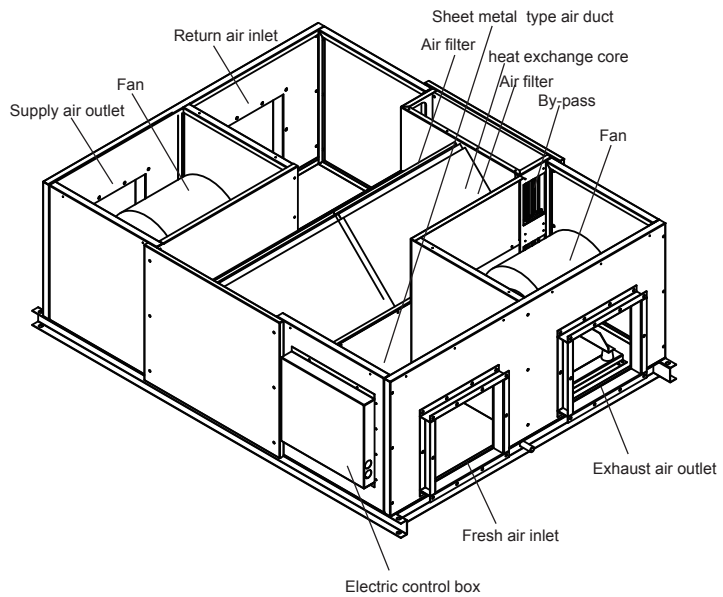



CONTENTS	PAGE
PRECAUTIONS.....	1
ACCESSORY.....	1
INSTALLATION.....	2
WIRING.....	6
SPECIFICATION PARAMETER.....	10
KRE APPLICATION.....	11
MAINTENANCE AND UPKEEP.....	11
TRAIL RUN.....	11
ERP INFORMATION.....	12

## 1. PRECAUTIONS

To prevent injury to the user or other people and property damage, the following instructions must be followed. Incorrect operation due to ignoring of instructions may cause harm or damage. The appliance should be installed by a professional in accordance with the specified instructions.

The safety precautions listed here are divided into two categories. In either case, important safety informations are listed which must be read carefully.



### WARNING

Failure to observe a warning may cause electric shock, fire hazard or personal injury



### CAUTION

Failure to observe a caution may cause injury or damage to the equipment.



### WARNING

- Ask your dealer or qualified personnel to carry out installation work. Do not try to install the machine by. Incorrect installation may result in leakage, electric shocks or fire.
- Installation should be done by following the installation manual and no changes should be made to the unit. Incorrect installation may cause leakage, electric shock, or fire. If the KRE falls, it may cause damage and injury.
- Install the unit on a foundation that is strong enough to withstand the weight of the unit.  
A foundation of insufficient strength may result in the equipment falling and causing injuries.
- Do not allow exhaust air to enter the outside air inlet.  
This may cause the air of the room to become contaminated, harming the health.
- Locate the outside air intake vent so that it does not take in exhaust air which contains combustion air, etc.  
Incorrect installation may cause a loss of oxygen in the room, leading to serious accidents.
- Make sure that a separate power supply circuit is provided for this unit and that all electrical work is carried out by qualified personnel according to local laws and regulations and this installation manual.  
Insufficient power capacity, improper electrical works, or incorrect wiring may cause electric shock or fire.

- Make sure Earth Leakage Breaker is the type of all poles drop-out.
- Be sure to ground.  
Do not connect the ground wire to gas or water pipes, lightning rod or a telephone ground wire.  
Incomplete grounding may result in electric shocks.
- Make sure that all wiring is secured, the specified wires are used, and no external forces act on the terminal connections or wires.  
Improper connections or installation may result in overheating or fire.
- When wiring the power supply and connecting the remote controller wiring and transmission wiring, position the wires so that the electric parts box lid can be securely fastened.  
Improper positioning of the electric parts box lid may result in electric shocks, fire or the terminals overheating.



### CAUTION

- Be sure to install an earth leakage breaker.  
Failure to install an earth leakage breaker may result in electric shocks.
- Install the indoor and outdoor units, power supply wiring and connecting wires at least 1 meter away from television or radio in order to prevent image interference or noise. (Depending on the radio waves, a distance of 1 meter may not be sufficient enough to eliminate the noise.)
- Install the two outdoor ducts with down slope to prevent rainwater from entering the unit.  
If this is not done completely, water may enter the building, may damage furniture, etc.
- Insulate the duct and the wall electrically when a metal duct is to be penetrated through the metal lattice and wire lattice or metal lining of a wooden structure wall.  
Improper duct work may cause electric shocks or short circuits.
- Make sure that a snow protection measure is taken. If no protection snow may enter through the outdoor ducts, and cause damaging furniture and electric shock and fire.

## 2. ACCESSORY

Table 2-1

Name	Qty.	Shape	Purpose
Installation and owner's manual	1	This manual	must be delivered to the customer

Notes: Wired controller should be purchased separately.

Prepare the following on site.

Table 2-2

Name	Purpose
PVC drain pipe	For connecting unit's drain pipe, which length is selected according to your actual requirement (Only required for Model 1500 and 2000)
Damper	For vibration damping, when lift the unit.

### 3. INSTALLATION

#### 3.1 Installation Preparation



#### WARNING

Keep all the accessories and tools until installation work is completed.

- Leave the unit inside its packaging while moving, until reaching the installation site. Where unpacking is unavoidable, use a sling of soft material or protective plates together with a rope when lifting, to avoid damage or scratches to the unit.
- Hold the unit by the hanger brackets when opening the crate and moving it, and do not lift it holding on to any other part (especially the duct connecting flange).



#### NOTE

Be sure to instruct customers how to properly operate the unit (especially maintenance of air filter, and operation procedure) by having them carry out operations themselves while looking at the manual.

#### 3.2 Select The Installation Site



#### CAUTION

When moving the unit during or after unpacking, make sure to lift it by holding its hanger brackets. Do not exert any pressure on other parts, especially duct connecting flange.

- Select an installation site where the following conditions are fulfilled and meet with your customer's approval.
- KRE should be installed far away from office, recreation or any other places where silent environment are required. (install that in special machine room or wash room is recommended)
- install in a place which has sufficient strength and stability. (Beam, ceiling and other locations capable of fully supporting the weight of the unit.) Insufficient strength is dangerous. It may also cause vibration and unusual operating noise.
- Do not install the unit directly against a ceiling or wall. (If the unit is in contact with the ceiling or wall, it can cause vibration.)
- Where sufficient clearance for maintenance and service can be ensured.



#### CAUTION

- Install the units, power supply wiring and connecting wires at least 1 meter away from televisions or radios in order to prevent interference or noise. (Depending on the radio waves, a distance of 1 meter may not be sufficient enough to eliminate the electric interference.)
- The bellows may not be able to be used in some districts, so exercise caution. contact your local government office or fire department for details.
- When discharging exhaust air to a common duct, the Building Standard Law requires the use of fire proof materials, so attach a 2m copper plate standing duct.

- Do not install the unit in the following locations:
- Place subjected to high temperature or direct flame. May result in fire or overheating.
- Place such as machinery plant and chemical plant where gas, which contains noxious gas or corrosive components of materials such as acid, alkali organic solvent and plait, is generated. Place where combustible gas leakage is likely. Copper piping and brazed joints may corrode, causing refrigerant to leak or poisoning and fire due to leaked gas.
- Place such as bathroom subjected to moisture. Electric leak or electric shocks and other failure can be caused.
- Near machinery emitting electromagnetic waves. Electromagnetic waves may disturb the operation of the control system and result in a malfunction of the equipment.

#### 3.3 Preparations Before Installation

- Confirm the positional relationship between the unit and suspension bolts. Leave space for servicing the unit and include inspection hatches. (Always open a hole on the side of the electric parts box so that the air filters, heat exchange elements, fans, be easily be inspected and serviced.)
- Make sure the range of the unit's external static pressure is not exceeded.
- Open the installation hole (Pre-setting ceilings) Once the installation hole is opened in the ceiling where the unit is to be installed, pass transmission wiring, and remote controller wiring to the unit's wiring holes. After opening the ceiling hole, make sure ceiling is level if needed. It might be necessary to reinforce the ceiling frame to prevent shaking. Please consult architect or woodworker, if necessary.
- Install the suspension bolts. (Use M10 to M12 suspension bolts.) Use a hole-in anchor, sunken insert anchor for existing ceilings, or other parts to be procured in the field to reinforce the ceiling to bearing the weight of the unit.
- Install vibration damping feet. (For vibration damping)

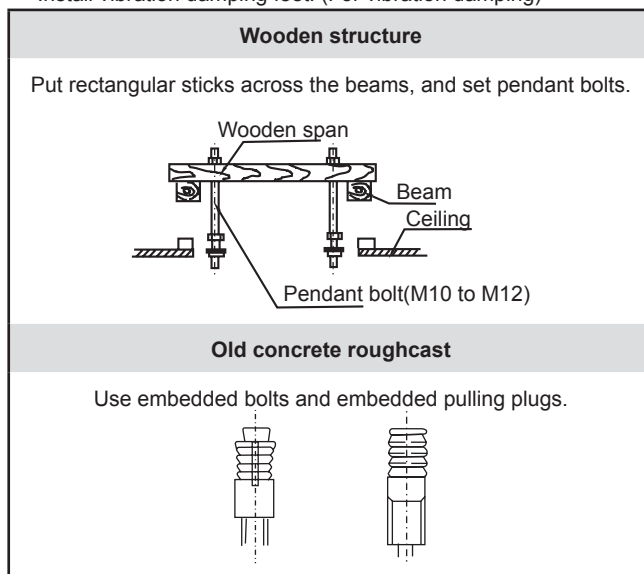

Fig. 3-1

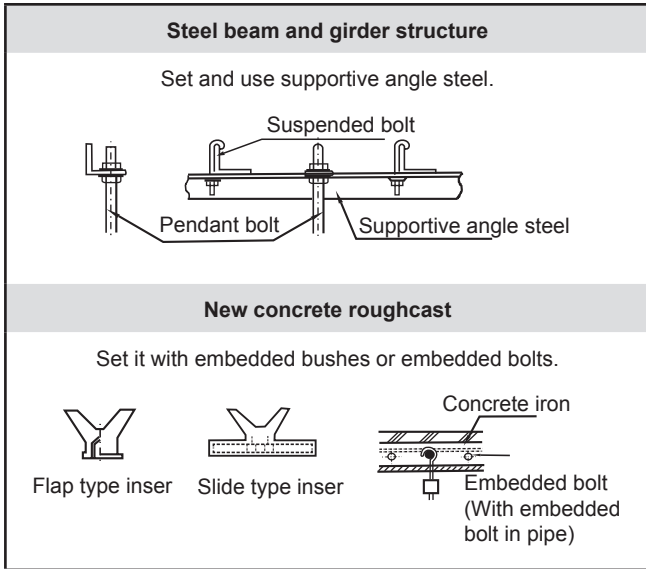

Fig. 3-2

### 3.4 Installation

- Before installation, please confirm all external parts are stand in their place and without damage.
- The surrounding environment of the unit, especially the sides of wiring cabinet and water collecting side should reserve sufficient wiring and maintenance and space; additionally, one should ensure the removing space for filter griller.
- Unit should mount steadily and without sustain the weight form condensate water pipe and air duct. The vents of air inlet/outlet and return should be connected with flexible tube.
- Unit in AC 220-240V/50Hz, reliable grounding; each one possesses of independent cut-off and protection device.
- The installation dimension and maintenance space. (See the following attached picture Fig.3-3 )
- Operating conditions  
For proper performance, run the air conditioner under the following temperature conditions:

<b>OPERATION</b>	Outdoor air TEMP.	-7°C~43°C
	Room TEMP.	0°C~43°C
	Room humidity	Lower than 80% If higher than 80%, the surface of indoor unit may be condensed or the condensate will be blown from air outlet.

Protection or error may occur if running the unit beyond the above condition, and will cause unit stop running.

Unit : mm

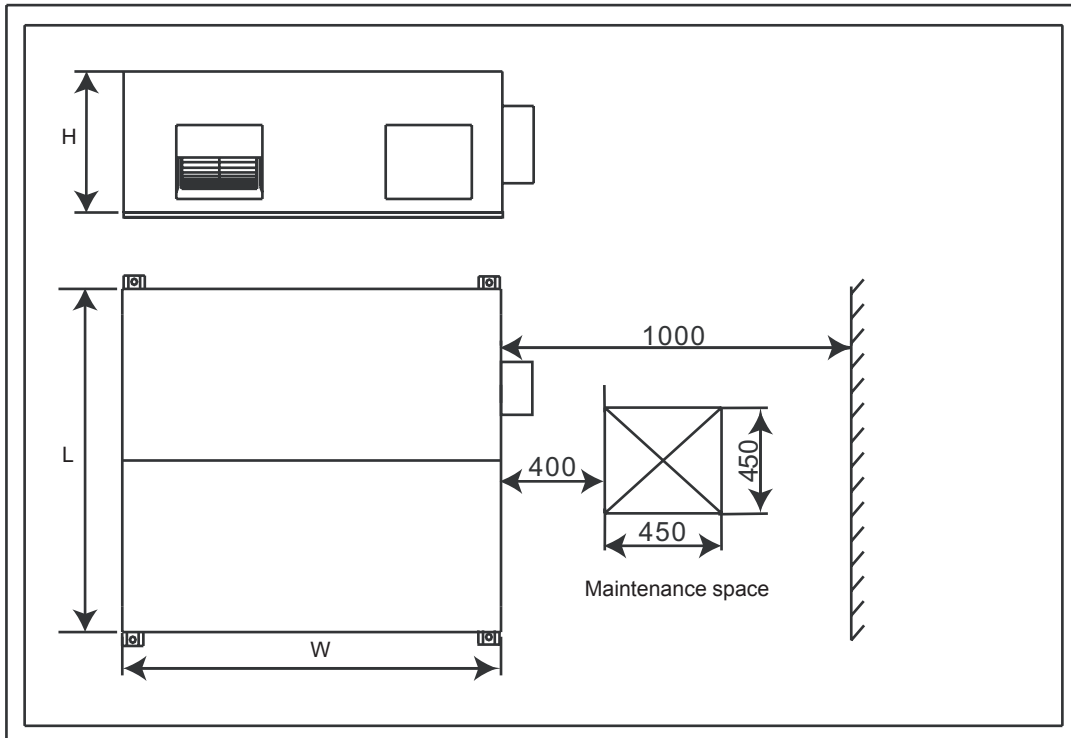

multiple indoor units (see Figure 7.8);

Key dimensions of the unit and air duct installation. (See the following pictures Fig.3-4~3-7 & Table 3-1 )

### KRE-500D1~KRE-1000D1

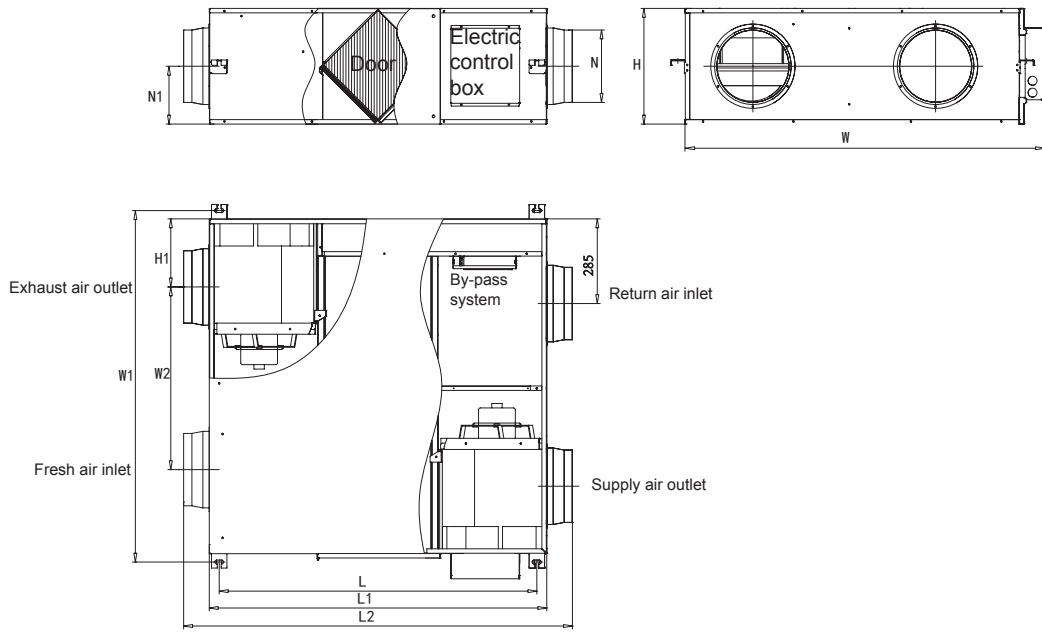

Fig. 3-5

Table 3-1 (Unit:mm)

Model	L	L1	L2	W1	W2	W	H	H1	N	N1
KRE-500D1	1071	1138	1311	1005	465	1106	390	227	Φ244	195
KRE-1000D1	1071	1138	1311	1431	764	1526	390	230	Φ244	195



# KRE-1500D1

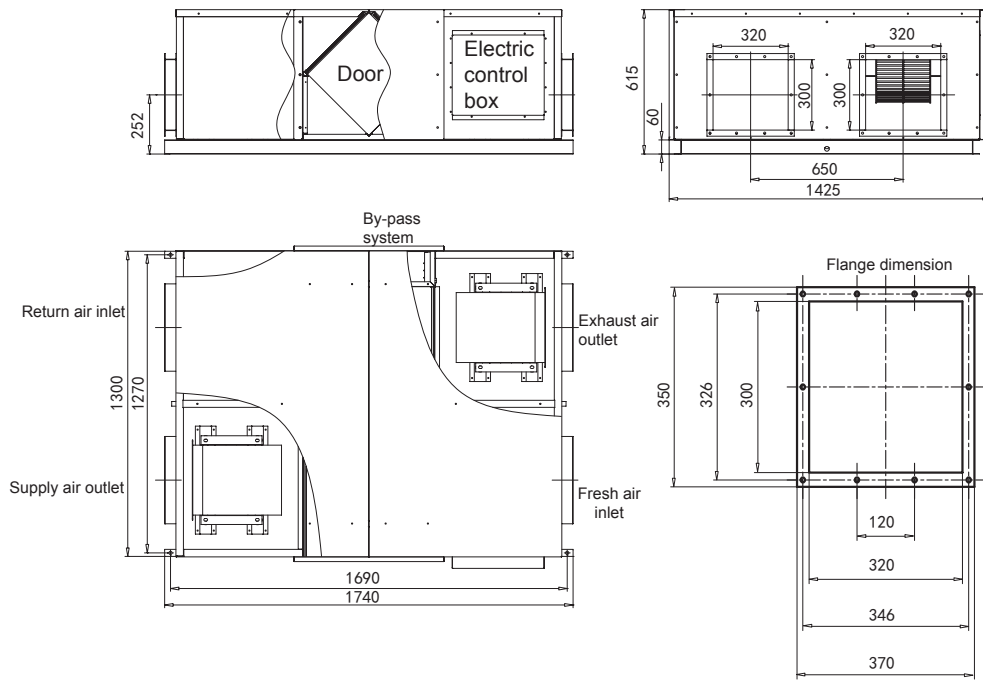

Fig. 3-6

# KRE-2000D1

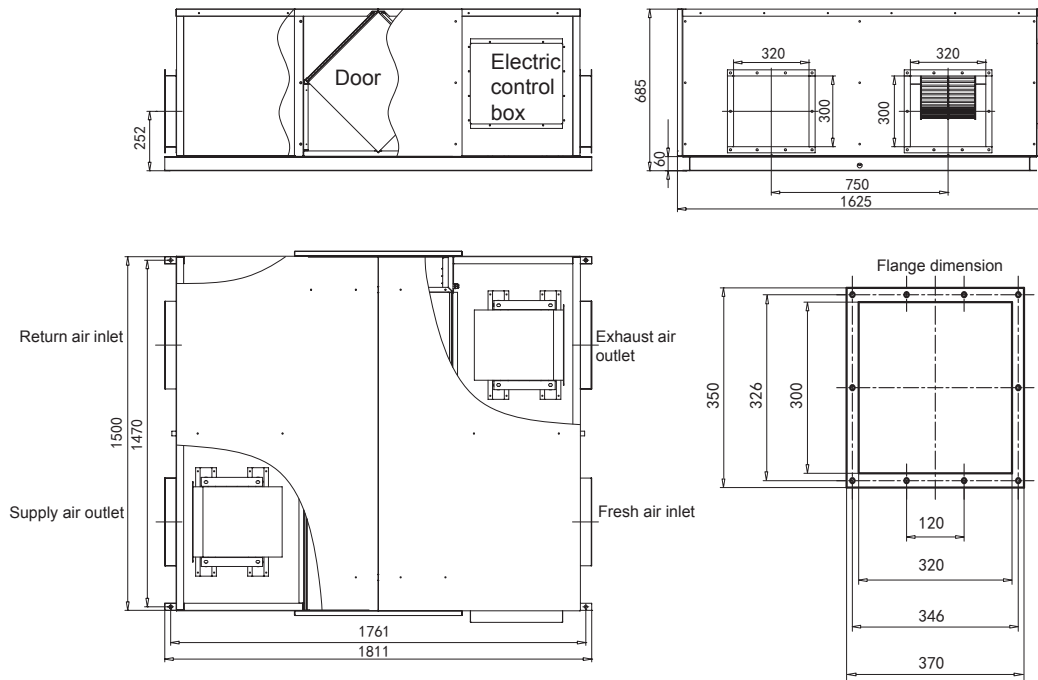

Fig. 3-7

## 4. WIRING

### Warning

- All the supplied parts, materials and electrical works must comply with local regulations.
- Only use copper wires.
- Use a steady power supply for the air-conditioners. The power voltage must be in line with the rated voltage.
- The electrical wiring works must be carried out by a professional technician, and must comply with the labels stated in the circuit diagram.
- Before the electrical connection works are carried out, turn off the power supply to prevent injuries caused by electric shock.
- The external power supply circuit of the air conditioner must include an earth line, and the earth line of the power cord connecting to the indoor unit must be securely connected to the earth line of the external power supply.
- Leakage protective devices must be configured according to the local technical standards and requirements for electrical and electronic devices.
- The fixed wiring connected must be equipped with an all-pole disconnection device with a minimum 3 mm contact separation.
- The distance between the power cord and signal line must be at least 300 mm to prevent the occurrences of electrical interference, malfunction or damage to electrical components. At the same time, these line must not be in contact with the piping and valves.
- Choose electrical wiring that conforms to the corresponding electrical requirements.
- Connect to the power supply only after all the wiring and connections have been completed, and check carefully if the connection is correct.

figure of the power supply terminal

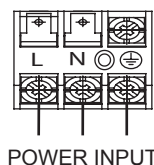

Fig. 4-1

When connecting to the power supply terminal, use the circular wiring terminal with insulation. Use power cord that conforms to the specifications and connect the power cord firmly. To prevent the cord from being pulled out by external force, make sure it is fixed securely. If circular wiring terminal with insulation cannot be used, please make sure that:

- Do not connect two power cords with different diameters to the same power supply terminal (may cause overheating).

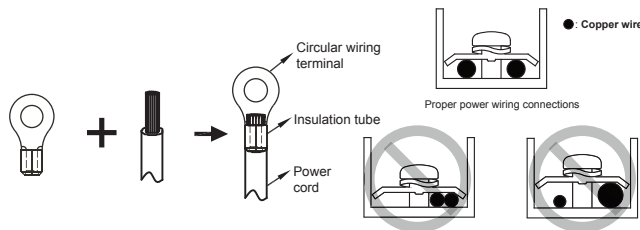

Fig. 4-2

Fig. 4-3

## 4.1 Electric data Specification

Table 4-1

Model KRE-D200~ 2000(B)		
Power supply	Phase	Single phase
	Voltage /frequency	220-240V/50Hz
Input current Main switch /fuse(A)		15/30
Power supply wireDimension	Wire's qty	3 (Earthing line should be used yellow/green wire.)
	Wire cross-section (mm <sup>2</sup> )	2.5

- After wiring, please confirm all connections are correct, and then power to the unit.
- Pay attention to the power supply wire of three-phase model; confirm the phase sequence of which is correct.

Table 4-2

ENC1 Settings for Capacity SW1 Setting for static pressure

ENC1	Capacity setting
0	200
1	300
2	400
3	500
4	800
5	1000
6	1500
7	2000

SW1-1	ON		Low static pressure
	OFF		High static pressure
SW1-2	ON		KRE centralized control
	OFF		KRE single unit operation
SW2-1	ON		With PRO
	OFF		Without PRO
SW2-2	ON		Positive Pressure
	OFF		Negative Pressure
SW2-3	ON		SW2 -2
	OFF		Balance Pressure

### Caution

- Positive Pressure: In the positive pressure mode, the supply fan operating fan speed is higher than the exhaust fan.
- Negative Pressure: In the negative pressure mode, the exhaust fan operating fan speed is higher than the supply fan.
- Balance Pressure: In the balance pressure mode, the supply fan operating wind gear is equal to the exhaust fan.

Table 4-3 Code and Definitions

Operation lamp	Flashing times	Show on centralized controller	Explanation
●	/	/	Unit is ON
○	/	/	Unit is OFF
★		E2	Indoor temperature sensor error
★	4	E5(new protocol) EF(old protocol)	Outdoor temperature sensor error
★	6	E7	EEPROM error
★	8	E6	DC fan motor error
★	10	OFF LINE	Without address
★	12	E1	Communication error with ODU
★	14		Ip address Conflict
★	16	EU	error with sensor board
★	18	FC	error with CO2 sensor
		E9	wire controller communication failure
		Ed	Outdoor unit failure

NOTE: ●:Light ; ○:Extinguish ; ★:Quick flash

Table 4-4 Terminal Definition

CODE	CN8	CN9	CN32	CN33	CN7	CN3	CN4	CN21
NAME	P Q E	X Y E	Modbus RTU	D1D2E	X1X2	Indoor temp. Sensor	Outdoor temp. Sensor	PRO

Dry contact (In put)	CN31	Inlet air pre-heat Signal
	CN16	Force to exhaust air mode
	CN26	Remote ON/OFF
Dry contact (Out put)	CN14	Signal for ventilation fan
	CN15	Alarm
	CN20	Signal for inlet air Pre-heat

### Communication wiring between the indoor and outdoor units

The KRE and outdoor units communicate via the RS485 serial port.

The communication wiring between the KRE and outdoor units should be connected one unit after another in a daisy chain from the outdoor unit to the final KRE unit. And the shielded layer must be properly grounded, and a build-out resistor must be added to the last KRE unit to enhance the stability of the communication system.

Incorrect wiring such as a star connection or a closed ring will cause instability of the communication system and system control anomalies.

Use a three core shielded wire (greater than or equal to 0.75 mm<sup>2</sup>) for the communication wiring between the indoor and outdoor units. Make sure the wiring is connected correctly. The connecting lead for this communication wire must come from the master outdoor unit. All shielded wiring in the network are interconnected, and will eventually connect to earth at the same point "⊕".

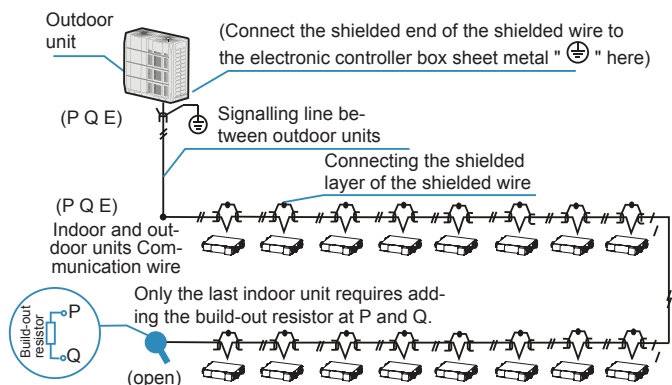

### Communication wiring between the indoor unit and wired controller

The wired controller and the indoor unit can be connected in different manners, depending on the forms of communication.

1. For a bidirectional communication mode:

- Use 1 wired controller to control 1 indoor unit or 2 wired controllers (one master and one slave controller) to control 1 indoor unit. (see Fig.4-4)
- Use 1 wired controller to control multiple indoor units or 2 wired controllers (one master and one slave controller) to control multiple indoor units. The maximum number of connections is 16. (see Fig.4-5)

2. For single direction communication mode:

- Use 1 wired controller to control 1 indoor unit
- The X1/X2, D1/D2 ports on the sides of the main control board and single direction communication port are for different types of wired controllers.
- For the specific connection method, refer to the instructions in the corresponding wired controller manual to carry out the wiring and connections.

### Handling the Electrical Wiring Connection Points

- Once the wiring and connections are done, use tie straps to secure the wiring properly so that the connection joint cannot be pulled apart by external force. The connection wiring must be straight out so that the cover of the electrical box is level and can be closed tightly.
- Use professional insulation and sealing materials to seal and protect the perforated wires. Poor sealing may lead to condensation, and entry of small animals and insects that may cause short circuits in parts of the electrical system, causing the system to fail.

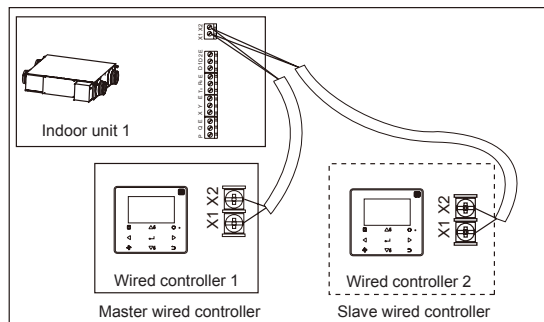

Fig. 4-4

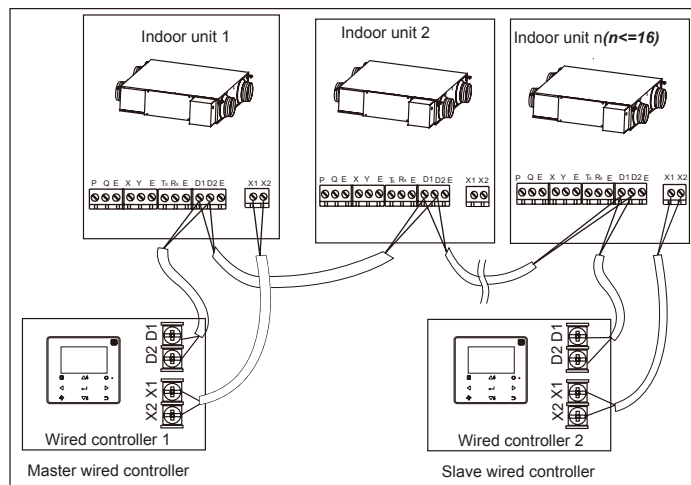

Fig. 4-5

### Operatio Manual

There are two types of precautions as described below:

**Warning:** Failure to comply may lead to serious injury.

**Caution:** Failure to comply may lead to injury or damage of the unit. Depending on the situation, this may also lead to serious injury. Once the installation is completed, please keep the manual properly for future reference. When this air conditioner is handed over to other users, make sure that the manual is included with the handover.

**Warning**

- Do not use this unit in locations where flammable gas may exist. If flammable gas comes into contact with the unit, a fire may occur, which could result in serious injury.
- If this unit exhibits any abnormal behavior (such as emitting smoke) there is a danger of serious injury. Disconnect the power supply and contact your supplier or service engineer immediately.

- The refrigerant in this unit is safe and should not leak if the system is designed and installed properly. However, if a large amount of refrigerant leaks into a room, the oxygen concentration will decrease rapidly, which can cause serious injury. The refrigerant used in this unit is heavier than air, so the danger is greater in basements or other underground spaces. In the event of a refrigerant leak, turn off any devices that produce a naked flame and any heating devices, ventilate the room, and contact your supplier or service engineer immediately.
- Toxic fumes may be produced if the refrigerant in this unit comes into contact with naked flames (such as from a heater, gas stove/burners, or electric appliances).

- If this unit is used in the same room as a cooker, stove, hob, or burner, ventilation for sufficient fresh air must be ensured, otherwise the oxygen concentration will fall, which may cause injury.
- Dispose of this unit's packaging carefully, so children can't play with it. Packaging, especially plastic packaging, can be dangerous, can cause serious injury. Screws, staples and other metal packaging components can be sharp and should be disposed of carefully to avoid injury.
- Dispose of this unit's packaging carefully, so children can't play with it. Packaging, especially plastic packaging, can be dangerous, can cause serious injury. Screws, staples and other metal packaging components can be sharp and should be disposed of carefully to avoid injury.
- Do not attempt to inspect or repair this unit yourself. This unit should only be serviced and maintained by a professional air conditioning service engineer. Incorrect servicing or maintenance can cause electric shocks, fire or water leaks.
- This unit should only be re-positioned or re-installed by a professional technician. Incorrect installation can lead to electric shocks, fire or water leaks. The installation and grounding of electrical appliances should only be carried out by licensed professionals. Ask your supplier or installation engineer for further information.
- Do not allow this unit or its remote controller to come into contact with water, as this can lead to electric shocks or fire.
- Turn off the unit before cleaning it to avoid electric shocks. Otherwise, an electric shock and injury may result.
- To avoid electric shocks and fires, install an earth leakage detector.
- Do not use paint, varnish, hair spray, other flammable sprays or other liquids that may give off flammable fumes/vapor near this unit, as doing so can cause fires.
- When replacing a fuse, ensure that the new fuse to be installed completely complies with requirements.
- Do not open or remove the unit's panel when the unit is powered on. Touching the unit's internal components while the unit is powered on can lead to electric shocks or injuries caused by moving parts such as the unit's fan.
- Ensure that the power supply is disconnected before any servicing or maintenance is carried out.
- Do not touch the unit or its remote controller with wet hands, as doing so can lead to electric shocks.
- Do not allow children to play near this unit, as doing so risks injury.
- Do not insert your fingers or other objects into the unit's air inlet or air outlet to avoid injury or damage to the equipment.
- Do not spray any liquids onto the unit or allow any liquids to drip onto the unit.
- Do not place vases or other liquid containers on the unit or in places where liquid could drip onto it. Water or other liquids that come into contact with the unit can lead to electric shocks or fires.
- Do not remove the remote controller's front or back covers and do not touch the remote controller's internal components, as doing so can cause injury. If the remote controller stops working, contact your supplier or service engineer.
- Ensure that the unit is properly grounded, otherwise electric shocks or a fire may result. Electrical surges (such as those that can be caused by lightning) can damage electrical equipment. Ensure that suitable surge protectors and circuit breakers are properly installed, otherwise electric shocks or a fire may result.
- Dispose of this unit properly and in accordance with regulations. If electrical appliances are disposed of in landfills or dumps, hazardous substances can leak into the groundwater and thus enter the food chain.
- Do not use the unit until the qualified technician instructs you that it is safe to do so.
- Do not place appliances that produce naked flames in the path of the airflow from the unit. The airflow from the unit may increase the rate of combustion, which may cause a fire and cause serious injury. Alternatively, the airflow may cause incomplete combustion which can lead to reduced oxygen concentration in the room, which can cause serious injury.

 **Caution**

- Only use the air conditioner for its intended purpose. This unit should not be used to provide refrigeration or cooling for food, plants, animals, machinery, equipment or art.
- Do not insert your fingers or other objects into the unit's air inlet or air outlet to avoid injury or damage to the equipment.
- The fins on the unit's heat exchanger are sharp and can cause injury if touched. To prevent injury, when the unit is being serviced, gloves should be worn or the heat exchanger should be covered.
- Do not place items which might be damaged by moisture under the unit. When the humidity is greater than 80% or if the drain pipe is blocked or the air filter is dirty, water could drip from the unit and damage objects placed under the unit.
- Ensure that the drain pipe functions properly. If the drain pipe is blocked by dirt or dust, water leaks may occur when the unit is running in cooling mode. If this happens, turn the unit off and contact your supplier or service engineer.
- Do not touch the internal parts of the controller. Do not remove the front panel. Some internal parts may cause injury or be damaged.
- Ensure that children, plants and animals are not directly exposed to the airflow from the unit.
- When fumigating a room with insecticide or other chemicals, cover the unit well and do not run it. Failure to observe this caution could lead to chemicals getting deposited inside the unit and later emitted from the unit when it running, endangering the health of any room occupants.
- Do not dispose of this product as unsorted waste. It must be separately collected and processed. Ensure that all applicable legislation regarding the disposal of refrigerant, oil and other materials is adhered to. Contact your local waste disposal authority for information about disposal procedures.
- To avoid damaging the remote controller, exercise caution when using it and replacing its batteries. Do not place objects on top of it.
- Do not place appliances that have naked flames under or near the unit, as heat from the appliance can damage the unit.
- Do not place the unit's remote controller in direct sunlight. Direct sunlight can damage the remote controller's display.
- Do not use strong chemical cleaners to clean the unit, as doing so can damage the unit's display or other surfaces. If the unit is dirty or dusty, use a slightly damp cloth with very diluted and mild detergent to wipe the unit. Then, dry it with a dry cloth.
- Children shall not play with the appliance.



## CAUTION

1. Never turn screws too tightly, or else the cover would be dented or the Liquid Crystal breaks.
2. Please leave sufficient space for maintenance and service of wired controller.
3. Wired controller should be purchased separately.
4. Please follow the installation and owner's manual of wired controller.

## 5. SPECIFICATION PARAMETER

### 5.1 Specification Parameter

Table 5-1

Model	Power supply	Packing size(mm)	Air outlet dimension (mm)	Net weight (kg)	Static pressure (Pa)	Nominal air flow (m <sup>3</sup> /h)
KRE-500D1	220-240V~ 50Hz	1390×1244×540	Φ244	74.4	90	500
KRE-1000D1		1390×1670×540	Φ244	90	160	1000
KRE-1500D1		1830×1520×770	346×326	181.5	180	1500
KRE-2000D1		1900×1720×845	346×326	208.5	200	2000

Table 5-2

Model	Nominal temp. efficiency	Nominal enthalpy efficiency	Sound power level(dB)	Power input(kW)	Current(A)
KRE-500D1	80.6	74.0	50	0.15	1.2
KRE-1000D1	82.8	76.0	54	0.38	2.9
KRE-1500D1	75.5	69.4	69	0.68	3.8
KRE-2000D1	77.2	74.7	70	0.95	5.7

#### Notes:

There are 3 steps of fan speed (High, Medium, Low), all the parameters in the above table is measured at the high speed.

## 6. KRE APPLICATION

### 6.1 Operation principle

KRE (Heat Recovery Ventilation) employ advanced technique and technics, the heat exchanged core forming by special paper that be processed with chemical treatment, which could create the optimum result in temperature, humidity and cooling recovery.

High efficiency heat exchanged core: When air flow formed by exhaust air and outdoor air through the heat exchanged core in cross way, because of temperature difference in the two sides of flat partition board, the heat transmission is occurred. In summer, outdoor air acquire cooling from air exhaust to decrease environment temperature; In winter, outdoor air acquire heat from air exhaust to increase temperature, that is to say, it realizing the energy recovery during air exhaust process to exchange the heat in heat exchanged core to outdoor air.

### 6.2 Pay Attention To The Following Items Before Operation

- 6.2.1. Before start-up, please clean up the duct and check whether all air valves and devices are normal.
- 6.2.2. Carefully adjust the system air valves when start-up, control the current of motor in rated range.
- 6.2.3. Three-phase model without by-pass function, therefore the fan would delay 30 seconds to start up.
- 6.2.4. Connect the wired controller  
Wired controller should be installed according to wired controller owner's manual, installation manual (Attached in the package box in wire controller).

## 7 MAINTENANCE AND UPKEEP

- 7.1 During early use, one should check the fan operation regularly.
- 7.2 The cleaning regulation for air filter depend on local environment. It could be clean by vacuum dirt exhauster or water, if heavy dust accumulates, it should use neutral detergent to clean it, and then dry it in shady and cool place for 20 to 30 minutes and replace it.
- 7.3 Clean the core at least 2 years a time by vacuum dirt exhauster to remove dust and foreign substance in the unit assemblies, do not touch the assemblies by exhauster and flush by water to avoid core damage.
- 7.4 Check the fan every half a year to maintain the well balance of it and check whether the axletree has loosed.

## 8. TRIAL RUN

### 8.1 Please Confirm The Following Points Before Trial Run:

- 8.1.1 The unit is installed correctly completed.
- 8.1.2 Ducting and wiring are correctly completed.
- 8.1.3 The drainage is smooth.
- 8.1.4 The heating insulation works well.
- 8.1.5 The ground wiring is connected correctly.
- 8.1.6 The power voltage fits the rated voltage of KRE.
- 8.1.7 There is no obstacle at the outlet and inlet of KRE.

### 8.2 Control The KRE By Wired controller, Operate It According To Wired controller Owner's Manual.

- 8.2.1 Whether the switch on the remote controller works well.
- 8.2.2 Whether the room temperature is adjusted well.
- 8.2.3 Whether the indicator lights normally.
- 8.2.4 Whether there is vibration or abnormal noise during operation.

## 9. ERP INFORMATION

**Table 9-1**

<b>Fan Types</b>	<b>Centrifugal forward curved fan</b>		
Directive (or Standard) for Regulation		ErP Directive 2009/125/EC COMMISSION REGULATION (EU) No 327/2011	
<b>Model Name</b>	WZDK170-38G-2 +LX-245*203*12-48J 1320	Rev.	
Prepare by			

### Specified Information of Fan:

No.	Information Item	Comment
1	$\eta_{\text{target}} =$	32.5%
2	Overall efficiency( $\eta_e$ )=	33.02%
3	Pass or not (Criteria: $\eta_e \geq \eta_{\text{target}}$ )	Pass
4	Measurement category (A -D)	A
5	Efficiency category (static or total)	Static
6	Efficiency grade at optimum energy efficiency point	N =44.52
7	VSD is integrated within the fan	YES
8	Year of Manufacture	Ref. to the Unit Nameplate
9	Manufacturer's name and place of manufacture	Ref. to the Unit Nameplate
10.1	Rated motor power input(s) (kW), at optimum energy efficiency	0.1517 kw
10.2	Rated motor flow rate(s) at optimum energy efficiency	0.1614m <sup>3</sup> /s
10.3	Rated motor pressure(s) at optimum energy efficiency	270 Pa
11	Rotations per minute (R.P.M)at the optimum energy efficiency point	1320r/min
12	Specific ratio	1.001
13	Information relevant for facilitating disassembly, recycling or disposal at end-of-life	all materials can be recycled
14	Information relevant to minimize impact on the environment and ensure optimal life expectancy as regards installation, use and maintenance of the fan	For installation, the clearance of 500 mm shall be kept from inlet
15	Description of additional items used when determining the fan energy efficiency,such as ducts, that are not described in the measurement category and supplied with the fan.	Measurement category A, fan is free inlet and outlet conditions
16	Motor manufacturer	NIDEC SHIBAURA(ZHEJIANG)CORP.



**Table 9-2**

Fan Types	Centrifugal forward curved fan		
Directive (or Standard) for Regulation	ErP Directive 2009/125/EC COMMISSION REGULATION (EU) No 327/2011		
Model Name	WZDK750-38G-W-1+LX-261*234*15-48J 1300	Rev.	
Prepare by			

**Specified Information of Fan:**

No.	Information Item	Comment
1	$\eta_{\text{target}} =$	34.14%
2	Overall efficiency( $\eta_e$ )=	49.7%
3	Pass or not (Criteria: $\eta_e \geq \eta_{\text{target}}$ )	Pass
4	Measurement category (A -D)	A
5	Efficiency category (static or total)	Static
6	Efficiency grade at optimum energy efficiency point	N =59.51
7	VSD is integrated within the fan	YES
8	Year of Manufacture	Ref. to the Unit Nameplate
9	Manufacturer's name and place of manufacture	Ref. to the Unit Nameplate
10.1	Rated motor power input(s) (kW), at optimum energy efficiency	0.276 kw
10.2	Rated motor flow rate(s) at optimum energy efficiency	0.34m <sup>3</sup> /s
10.3	Rated motor pressure(s) at optimum energy efficiency	360 Pa
11	Rotations per minute (R.P.M)at the optimum energy efficiency point	1300r/min
12	Specific ratio	1.001
13	Information relevant for facilitating disassembly, recycling or disposal at end-of-life	All materials can be recycled
14	Information relevant to minimize impact on the environment and ensure optimal life expectancy as regards installation, use and maintenance of the fan	For installation, the clearance of 500 mm shall be kept from inlet
15	Description of additional items used when determining the fan energy efficiency, such as ducts, that are not described in the measurement category and supplied with the fan.	Measurement category A, fan is free inlet and outlet conditions
16	Motor manufacturer	Panasonic Appliances Motor(Hangzhou) Co.Ltd.

**Table 9-3 Required information for RVU in COMMISSION REGULATION (EU) No.1254/2014 ANNEX IV**

No.	Information Item	Comment			
1	Supplier's name	Kaysun			
2	Model name	KRE-500D1	KRE-1000D1	KRE-1500D1	KRE-2000D1
3	Declared typology	NRVU,BVU	NRVU,BVU	NRVU,BVU	NRVU,BVU
4	Type of drive	Multi-speed	Multi-speed	Multi-speed	Multi-speed
5	Type of HRS	Other	Other	Other	Other
6	Thermal efficiency(%)	80.6	82.8	75.5	77.2
7	Nominal flow rate(m <sup>3</sup> /s)	0.139	0.278	0.417	0.556
8	Electric power input(kW)	0.157	0.383	0.677	0.956
9	SFPint(W/(m <sup>3</sup> /h))	682	785	702	730
10	Face velocity(m/s)	0.66	0.87	1.0	1.0
11	Nominal external pressure(Pa)	96	160	180	200
12	Internal pressure drop(Pa)	189	384	253	322
13	Internal pressure drop of non-ventilation components(Pa)	-	-	-	-
14	Efficiency in Regulation (EU) NO 327/2011	Out of scope	33	49.7	49.7
15	Maximum leakage rate(%)	10 Or less	10 Or less	10 Or less	10 Or less
16	Energy classification of the filters	-	-	-	-
17	Visual filter warning	Refer to instruction book			
18	Casingsound power level(dB)	50	54	69	70





**Kaysun**  
by **frigicoll**

**MAIN OFFICE**

Blasco de Garay, 4-6  
08960 Sant Just Desvern  
(Barcelona)  
Tel. +34 93 480 33 22  
<http://www.frigicoll.es/>  
<http://www.kaysun.es/en/>

**MADRID**

Senda Galiana, 1  
Poligono Industrial Coslada  
Coslada (Madrid)  
Tel. +34 91 669 97 01  
Fax. +34 91 674 21 00  
[madrid@frigicoll.es](mailto:madrid@frigicoll.es)