

Cassettes 600x600 & 840x840

Multisystem

PRODUCT SHEET



KID-05 S
Standard controller

Product certified by: 



FEATURES

Model	KCI-26 DMR13	KCI-35 DR13	KCI-52 DR13	KCI-71 DR13
Cooling capacity	2,64 kW	3,52 kW	5,28 kW	7,03 kW
Heating capacity	2,93 kW	3,81 kW	5,57 kW	7,62 kW
Airflow	450/500/580 m ³ /h	389/485/569 m ³ /h	479/584/680 m ³ /h	1.000/1.140/1.300 m ³ /h
Sound pressure	29/33/38 dB(A)	34,5/37,5/42 dB(A)	39/44/45,4 dB(A)	39,5/42,5/45,5 dB(A)
Power supply	220-240 V / 1 / 50 Hz			
Communication wiring	(3+T)x2,50 mm ²	(3+T)x2,50 mm ²	(3+T)x2,50 mm ²	(3+T)x2,50 mm ²
Refrigerating pipes	Ø1/4" / Ø3/8"	Ø1/4" / Ø3/8"	Ø1/4" / Ø1/2"	Ø3/8" / Ø5/8"

WIRING DIAGRAM

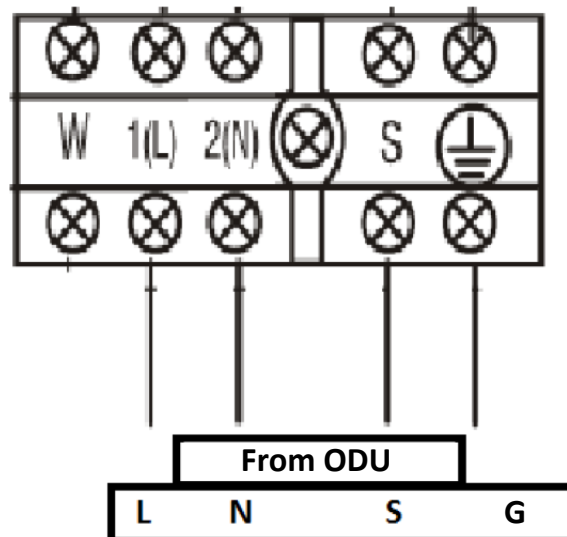

DIMENSIONS & WEIGHT OF INDOOR UNIT

Model	Weight
KCI-26 DMR11	14,70 kg
KCI-35 DR13	16,30 kg
KCI-52 DR13	16 kg

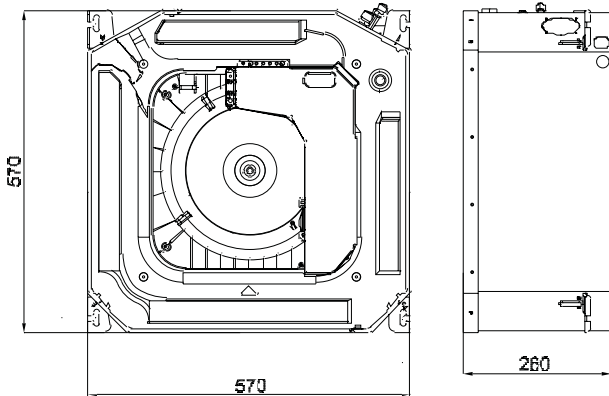

Model	Weight
KCI-71 DR13	21,60 kg

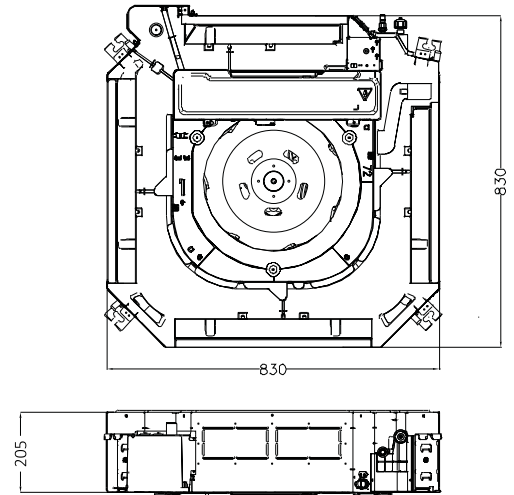

DIMENSIONS & WEIGHT OF PANEL

Model	Weight
KPA-03E 600X600	2,50 kg

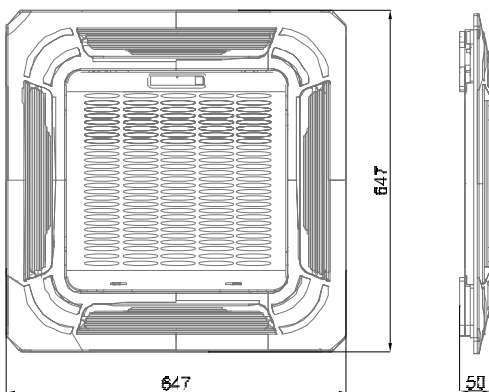

Model	Weight
KPA4-04B 840X840	6 kg

