

Cassette Artflux 360° 600x600

KCIF-17 DN4.0 / KCIF-22 DN4.0 / KCIF-28 DN4.0

PRODUCT SHEET

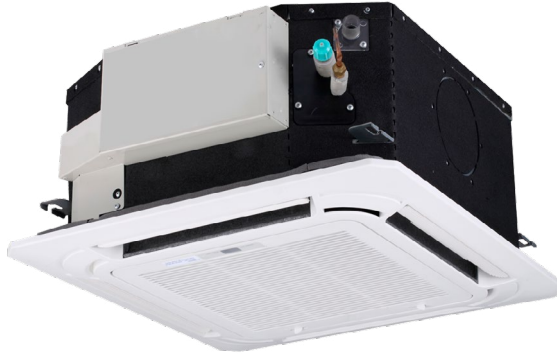

KI-04 S

Recommended controller

Product certified by: 



FEATURES

Model	KCIF-17 DN4.0	KCIF-22 DN4.0	KCIF-28 DN4.0
Cooling capacity	1,70 kW	2,20 kW	2,80 kW
Heating capacity	2,20 kW	2,40 kW	3,20 kW
Power input	35 W	35 W	35 W
Airflow	238/268/288/300/ 313/345/380 m ³ /h	405/441/462/503/ 524/552/576 m ³ /h	405/441/462/503/ 524/552/576 m ³ /h
Sound pressure	22/23/26/29 33/34/35 dB(A)	22/23/26/29/ 33/34/35 dB(A)	22/23/26/29/ 33/34/35 dB(A)
Pipe diameter	Ø1/4" / Ø1/2"	Ø1/4" / Ø1/2"	Ø1/4" / Ø1/2"
Drain tube diameter	Ø25 mm	Ø25 mm	Ø25 mm
Power supply	220-240 V / 1 / 50 Hz	220-240 V / 1 / 50 Hz	220-240 V / 1 / 50 Hz
Max. input	15 A	15 A	15 A
Power wiring	(2+T)x2,50 mm ²	(2+T)x2,50 mm ²	(2+T)x2,50 mm ²
Shielded communication wiring	3x0,75 mm ²	3x0,75 mm ²	3x0,75 mm ²

WIRING DIAGRAM

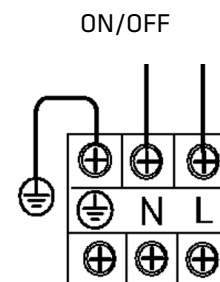
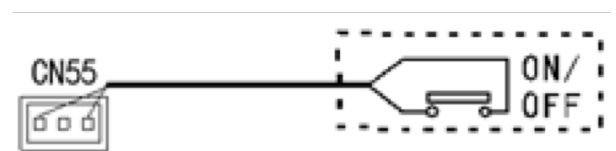
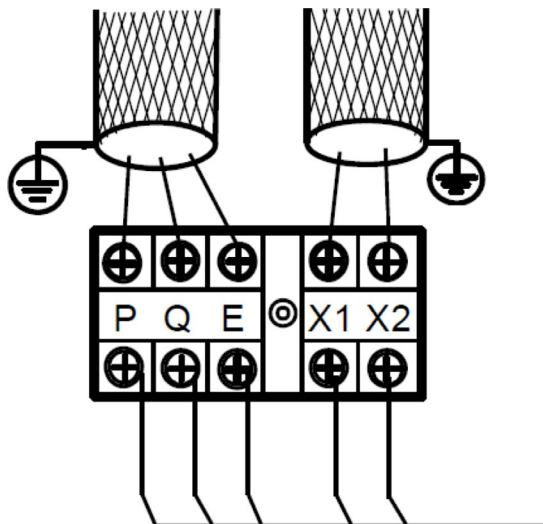

Power supply terminal

NOTES:

- (1) The data and specifications present in this sheet may vary without notice.
 (2) The images on this sheet are indicative and may be different from the final machine.

DIMENSIONS & WEIGHT

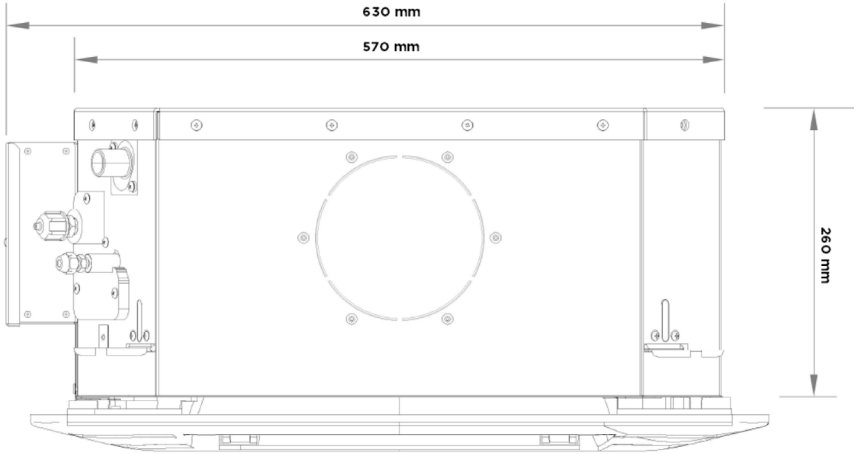
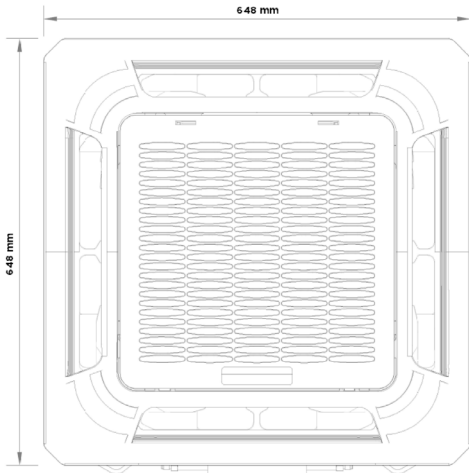
Model	KCIF-17 DN4.0	KCIF-22 DN4.0	KCIF-28 DN4.0
			
Weight	18 kg	18 kg	18 kg
Panel Model			
Weight	2,50 kg		

INSTALLATION

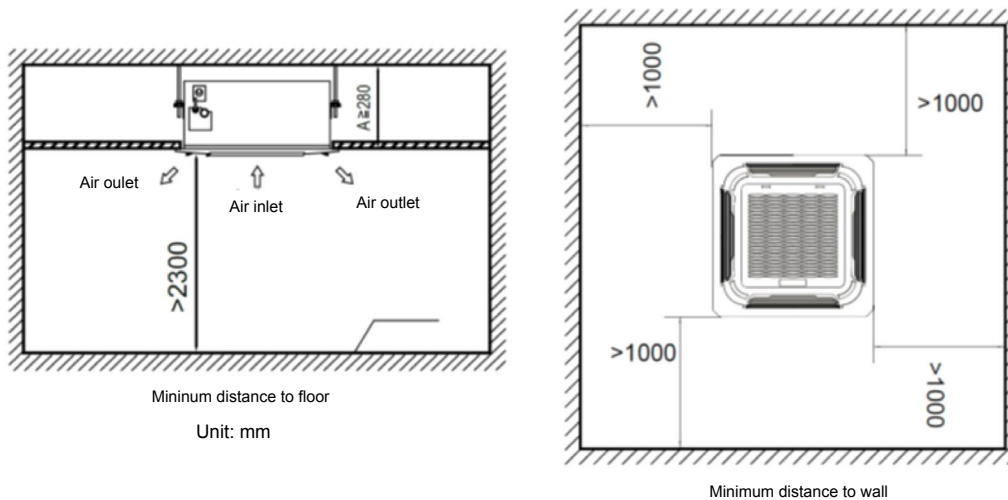

Cassette Artflux 360° 600x600

PRODUCT SHEET

KCIF-36 DN4.0 / KCIF-45 DN4.0 / KCIF-52 DN4.0

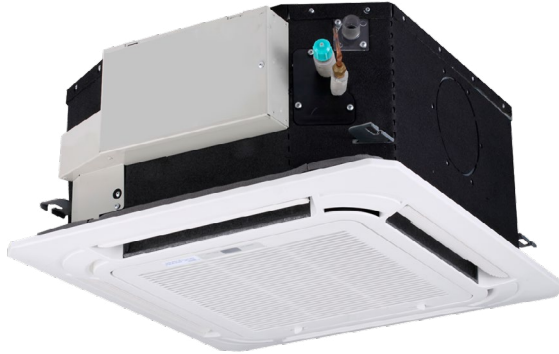

KI-04 S

Recommended controller

Product certified by: 



FEATURES

Model	KCIF-36 DN4.0	KCIF-45 DN4.0	KCIF-52 DN4.0
Cooling capacity	3,60 kW	4,50 kW	5,20 kW
Heating capacity	4 kW	5 kW	5,60 kW
Power input	40 W	50 W	62 W
Airflow	400/434/478/516/ 541/573/604 m ³ /h	400/434/478/516/ 541/573/604 m ³ /h	350/380/410/446/ 481/580/635 m ³ /h
Sound pressure	28/29/30/32/ 35/38/41 dB(A)	28/29/30/32/ 35/38/41 dB(A)	28/29/30/32/ 35/48/52 dB(A)
Pipe diameter	Ø1/4" / Ø1/2"	Ø1/4" / Ø1/2"	Ø1/4" / Ø1/2"
Drain tube diameter	Ø25 mm	Ø25 mm	Ø25 mm
Power supply	220-240 V / 1 / 50 Hz	220-240 V / 1 / 50 Hz	220-240 V / 1 / 50 Hz
Max. input	15 A	15 A	15 A
Power wiring	(2+T)x2,50 mm ²	(2+T)x2,50 mm ²	(2+T)x2,50 mm ²
Shielded communication wiring	3x0,75 mm ²	3x0,75 mm ²	3x0,75 mm ²

WIRING DIAGRAM

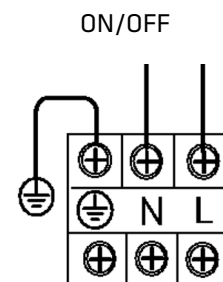
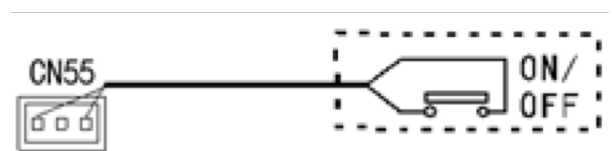
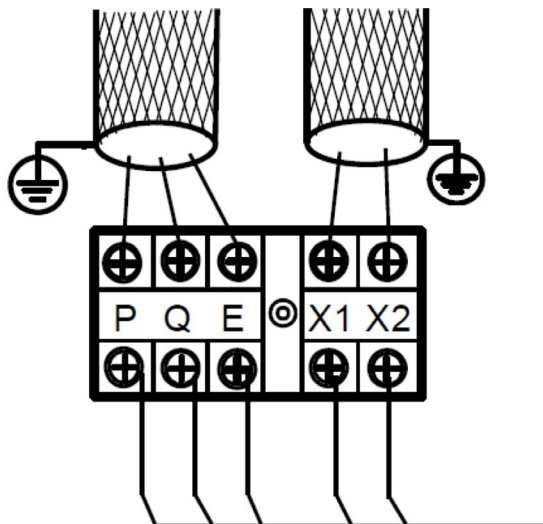

Power supply terminal

NOTES:

- (1) The data and specifications present in this sheet may vary without notice.
 (2) The images on this sheet are indicative and may be different from the final machine.

DIMENSIONS & WEIGHT

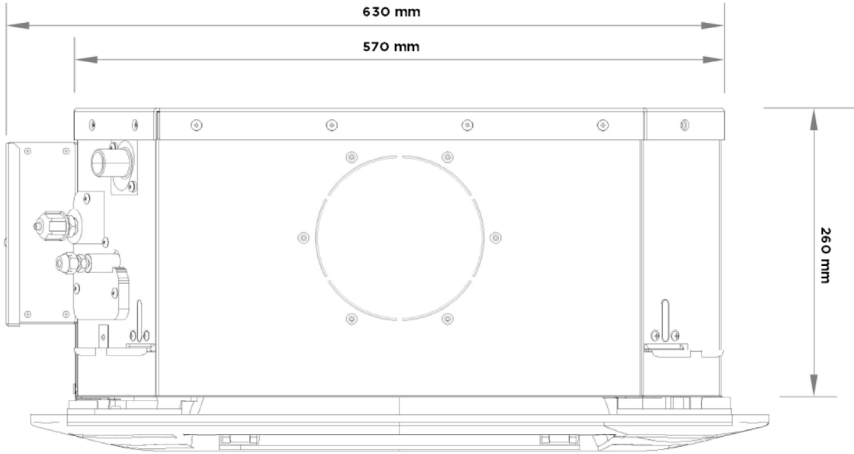
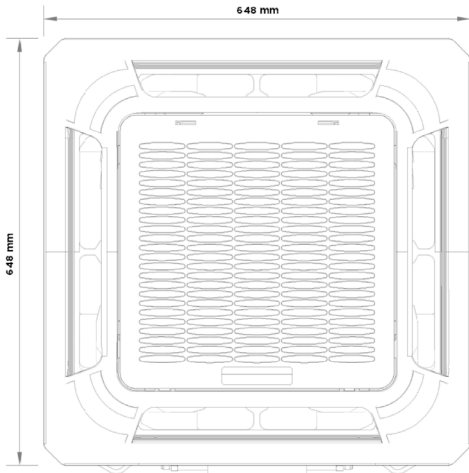
Model	KCIF-36 DN4.0	KCIF-45 DN4.0	KCIF-52 DN4.0
			
Weight	19,20 kg	19,20 kg	19,20 kg
Panel Model			
Weight	2,50 kg		

INSTALLATION

