

# Ducts

## Twins Axial

# PRODUCT SHEET



KC-03.1 SPS  
Recommended controller



## FEATURES

Indoor model / Outdoor model	2x KPD-71 DR11.1 / KUE-140 DTR11
Cooling capacity	7,03 kW
Heating capacity	7,62 kW
Airflow (indoor)	610/930/1.200 m <sup>3</sup> /h
Sound pressure (indoor)	25,50/29,10/32,80 dB(A)
Airflow (outdoor)	7.500 m <sup>3</sup> /h
Sound pressure (outdoor)	66 dB(A)
Power supply	380-400 V / 3 / 50 Hz
Max. input	13 A
Power wiring (indoor)	(2+T)x2,50 mm <sup>2</sup>
Power wiring (outdoor)	(4+T)x4 mm <sup>2</sup>
Communication wiring	2x1,50 mm <sup>2</sup>
Com. bus shielded	3x1,50 mm <sup>2</sup>

## WIRING DIAGRAM

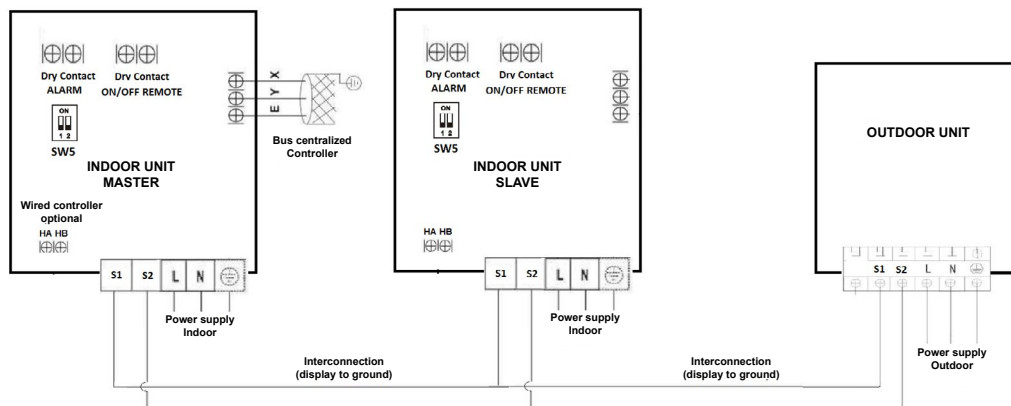

MASTER-SLAVE SELECTION				
SW5	<input type="checkbox"/>	<input type="checkbox"/>	<input type="checkbox"/>	<input type="checkbox"/>
MODE	1x1	MASTER	MASTER	SLAVE
FACTORY CONFIGURATION	✓			

### NOTES:

- (1) The data and specifications present in this sheet may vary without notice.  
 (2) The images on this sheet are indicative and may be different from the final machine.

## COOLING CONNECTION

Model	2x KPD-71 DR11.1 / KUE-140 DTR11	
Refrigerating pipes L	Ø3/8" / Ø5/8"	
Refrigerating pipes L1 & L2	Ø3/8" / Ø5/8"	
Refrigerant charge	2,80 kg	
Indoor drain pipe	Ø25	
Max. pipe length	65 m	
Max. level difference between outdoor & indoor unit	20 m	
Max. pipe length L1 & L2	15 m	
Difference between pipes L1-L2	10 m	
Max. level between indoor units	0,50 m	

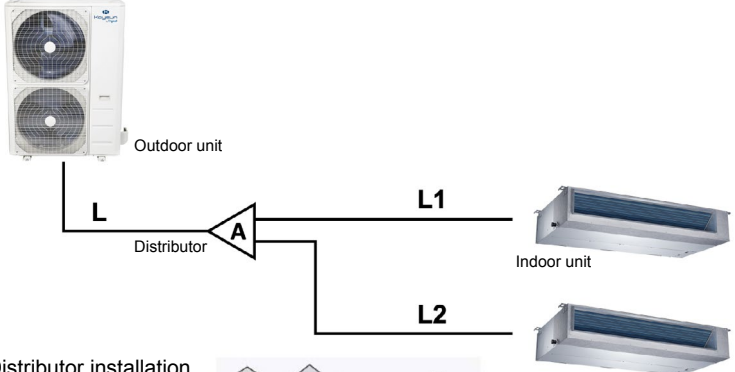

Distributor installation

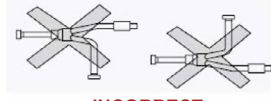

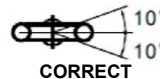

## DIMENSIONS & WEIGHT INDOOR

Model	KPD-71 DR11.1
A	1.100 mm
B	249 mm
C	774 mm
Weight	31,50 kg

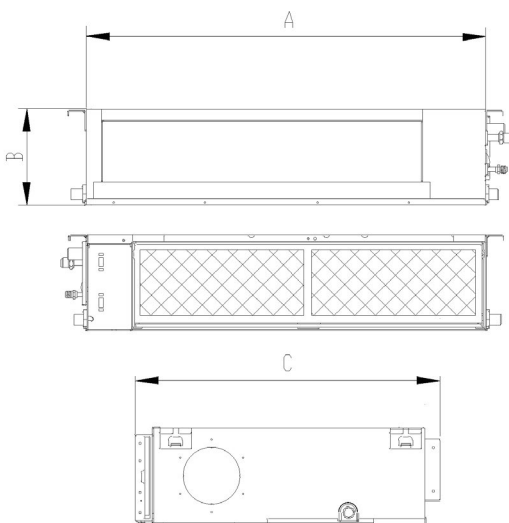

## DIMENSIONS & WEIGHT OUTDOOR

Model	KUE-140 DTR11
W	952 mm
H	1.333 mm
D	415 mm
Weight	106,70 kg

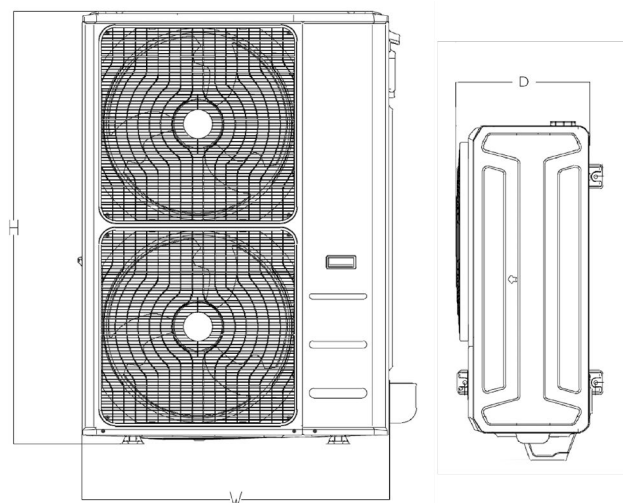

# Ducts Twins Axial

## PRODUCT SHEET



KC-03.1 SPS  
Recommended controller





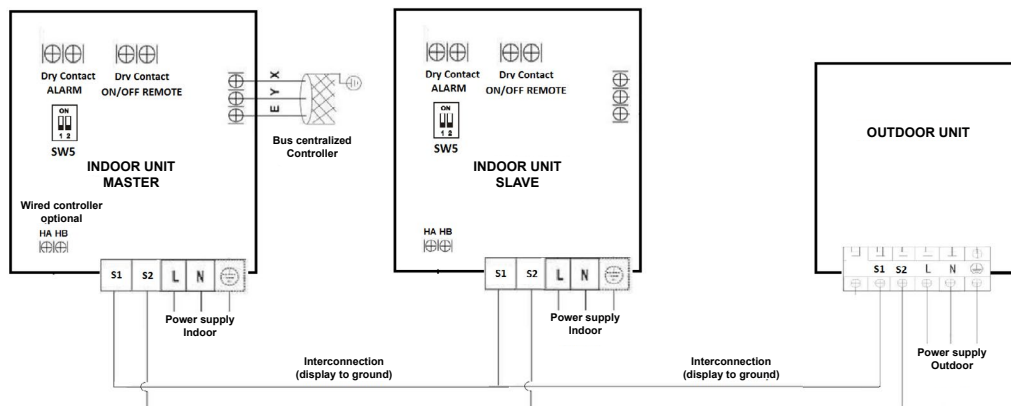

## FEATURES

Indoor model / Outdoor model	2x KPD-90 DR12.1 / KUE-160 DTR11
Cooling capacity	8,79 kW
Heating capacity	9,37 kW
Airflow (indoor)	1.560/1.780/2.060 m <sup>3</sup> /h
Sound pressure (indoor)	34,30/36,70/39,20 dB(A)
Airflow (outdoor)	7.500 m <sup>3</sup> /h
Sound pressure (outdoor)	66 dB(A)
Power supply	380-400 V / 3 / 50 Hz
Max. input	14 A
Power wiring (indoor)	(2+T)x2,50 mm <sup>2</sup>
Power wiring (outdoor)	(4+T)x6 mm <sup>2</sup>
Communication wiring	2x1,50 mm <sup>2</sup>
Com. bus shielded	3x1,50 mm <sup>2</sup>

## WIRING DIAGRAM



MASTER-SLAVE SELECTION				
SW5				
MODE	1x1	MASTER	MASTER	SLAVE
FACTORY CONFIGURATION	✓			

### NOTES:

- (1) The data and specifications present in this sheet may vary without notice.  
(2) The images on this sheet are indicative and may be different from the final machine.

## COOLING CONNECTION

Model	2x KPD-90 DR12.1 / KUE-160 DTR11	
Refrigerating pipes L	Ø3/8" / Ø5/8"	
Refrigerating pipes L1 & L2	Ø3/8" / Ø5/8"	
Refrigerant charge	2,80 kg	
Indoor drain pipe	Ø25	
Max. pipe length	65 m	
Max. level difference between outdoor & indoor unit	20 m	
Max. pipe length L1 & L2	15 m	
Difference between pipes L1-L2	10 m	
Max. level between indoor units	0,50 m	

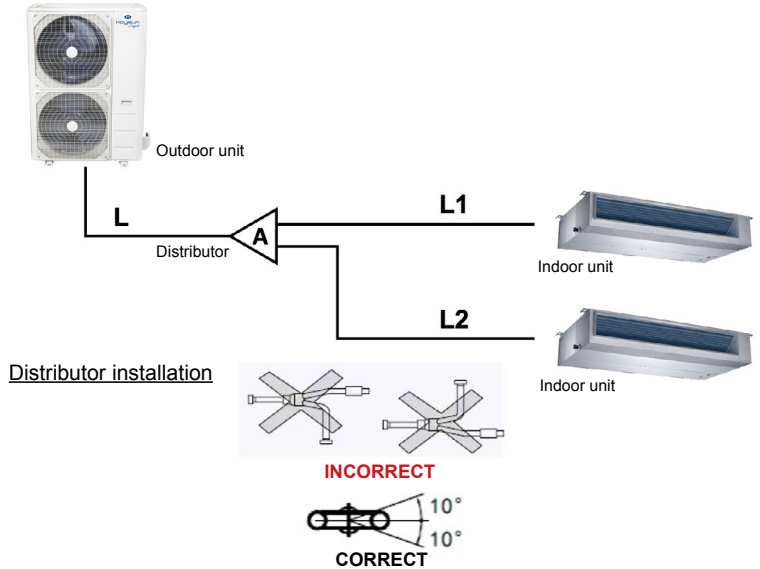

## DIMENSIONS & WEIGHT INDOOR

Model	KPD-90 DR12.1
A	1.360 mm
B	249 mm
C	774 mm
Weight	46,30 kg

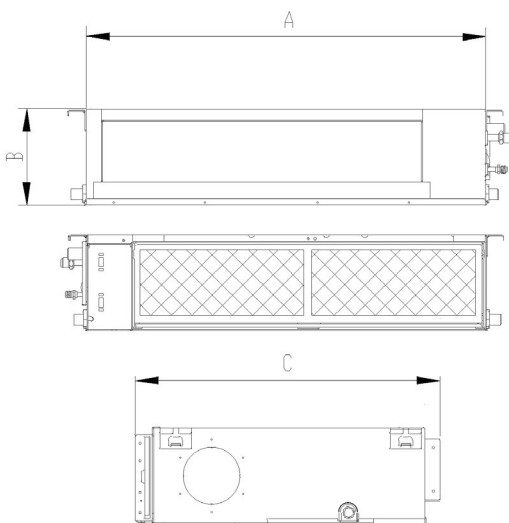

## DIMENSIONS & WEIGHT OUTDOOR

Model	KUE-160 DTR11
W	952 mm
H	1.333 mm
D	415 mm
Weight	111,30 kg

