



# OWNER'S & INSTALLATION MANUAL

## DC Inverter Air-cooled Modular Chiller

KEM-30 DRS4

KEM-60 DRS4



**IMPORTANT NOTE:**

Original instructions

Thank you very much for purchasing our air conditioner,

Before using your air conditioner, please read this manual carefully and keep it for future reference.

# CONTENTS

---





<b>ACCESSORIES .....</b>	<b>01</b>
<b>1 INTRODUCTION</b>	
• 1.1 Use conditions of the unit .....	01
<b>2. SAFETY CONSIDERATION.....</b>	<b>02</b>
<b>3 BEFORE INSTALLATION</b>	
• 3.1 Handling of the unit .....	04
<b>4 IMPORTANT INFORMATION ON REFRIGERANT.....</b>	<b>05</b>
<b>5 SELECTION OF INSTALLATION SITE .....</b>	<b>05</b>
<b>6 PRECAUTIONS ON INSTALLATION</b>	
• 6.1 Outline dimensional drawing .....	06
• 6.2 Requirements of arrangement space of the unit .....	07
• 6.3 Installation foundation .....	08
• 6.4 Installation of damping devices .....	08
• 6.5 Installation of device to prevent snow build-up and strong breeze.....	09
<b>7 CONNECTION DRAWING OF PIPELINE SYSTEM .....</b>	<b>10</b>
<b>8 OVERVIEW OF THE UNIT</b>	
• 8.1 Main parts of the unit.....	10
• 8.2 Opening the unit.....	11
• 8.3 System diagram .....	12
• 8.4 Outdoor unit PCBs .....	14
• 8.5 Electric wiring .....	17
• 8.6 Water system installation .....	24
<b>9 STRAT-UP AND CONFIGURATION .....</b>	<b>28</b>
• 9.1 Initial start-up at low outdoor ambient temperatures .....	28
• 9.2 Points for attention prior to trial run .....	28
<b>10 TEST RUN AND FINAL CHECK</b>	
• 10.1 Check item table after installation .....	29
• 10.2 Trial run .....	29

## **11 MAINTENANCE AND UPKEEP**

• 11.1 Failure information and code .....	30
• 11.2 Digital display of main board .....	32
• 11.4 Removing scale .....	32
• 11.5 Winter shutdown .....	32
• 11.6 Replacing parts .....	32
• 11.7 First startup after shutdown .....	33
• 11.8 Refrigeration system .....	33
• 11.9 Disassembling compressor .....	33
• 11.10 Auxiliary electric heater .....	33
• 11.11 System antifreezing .....	33
• 11.12 Replacement of safety valve .....	34
• 11.13 Information servicing .....	35
<b>RECORD TABLE OF TEST RUN AND MAINTENANCE .....</b>	<b>38</b>
<b>RECORD TABLE OF ROUTINE RUNNING .....</b>	<b>38</b>
<b>12 APPLICABLE MODELS AND MAIN PARAMETERS .....</b>	<b>39</b>
<b>13 INFORMATION REQUIREMENTS .....</b>	<b>40</b>

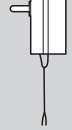

# ACCESSORIES

Unit	Installation & Operation Manual	Temperature testing components of total water outlet	Transformer	Installation manual of wired controller
Quantity	1	1	1	1
Shape				
Purpose	/	Use for installation (only need for setting the main module)		

## 1 INTRODUCTION

### 1.1 Use conditions of the unit

- 1) The standard voltage of power supply is 380-415V 3N~50Hz, the minimum allowable voltage is 342V, and the maximum voltage is 456V.
- 2) To maintain better performance, please operate the unit under the following outdoor temperature:

#### KEM-30 DRS4 KEM-60 DRS4

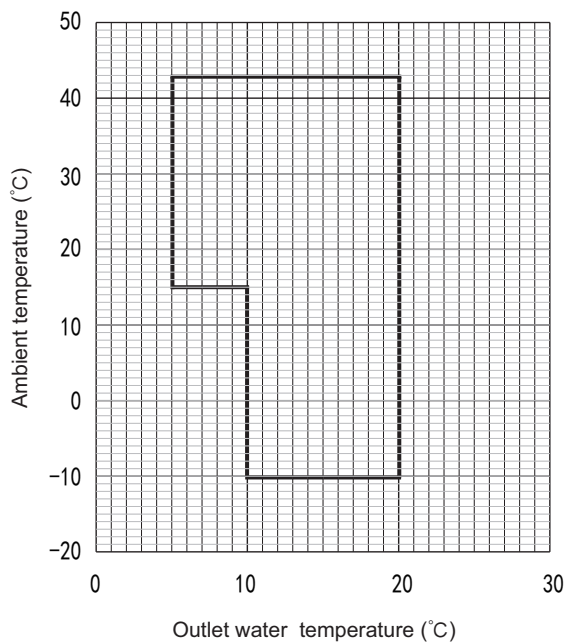

Fig. 1-1 Cooling operating range of KEM-30 DRS4 and KEM-60 DRS4

#### KEM-30 DRS4 KEM-60 DRS4

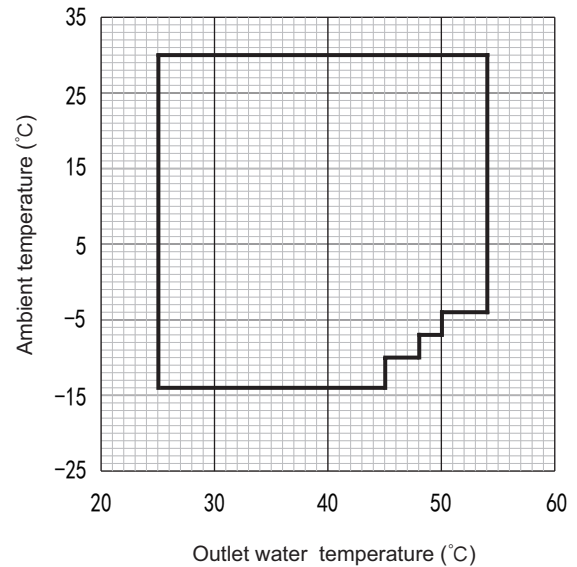

Fig. 1-2 Heating operating range of KEM-30 DRS4 and KEM-60 DRS4

## 2. SAFETY CONSIDERATION

The precautions listed here are divided into the following types. They are quite important, so be sure to follow them carefully. Meanings of DANGER, WARNING, CAUTION and NOTE symbols.

### INFORMATION

- Read these instructions carefully before installation. Keep this manual in a handy for future reference.
- Improper installation of equipment or accessories may result in electric shock, short-circuit, leakage, fire or other damage to the equipment. Be sure to only use accessories made by the supplier, which are specifically designed for the equipment and make sure to get installation done by a professional.
- All the activities described in this manual must be carried out by a licensed technician. Be sure to wear adequate personal protection equipment such as gloves and safety glasses while installation the unit or carrying out maintenance activities.
- Contact your dealer for any further assistance.

### DANGER

Indicates an imminently hazardous situation which if not avoided, will result in serious injury.

### WARNING

Indicates a potentially hazardous situation which if not avoided, could result in serious injury.





### CAUTION

Indicates a potentially hazardous situation which if not avoided, may result in minor or moderate injury. It is also used to alert against unsafe practices.

### NOTE

Indicates situations that could only result in accidental equipment or property damage.

### Explanation of symbols displayed on the indoor unit or outdoor unit

	WARNING	This symbol shows that this appliance used a flammable refrigerant. If the refrigerant is leaked and exposed to an external ignition source, there is a risk of fire.
	CAUTION	This symbol shows that the operation manual should be read carefully.
	CAUTION	This symbol shows that a service personnel should be handling this equipment with reference to the installation manual.
	CAUTION	This symbol shows that a service personnel should be handling this equipment with reference to the installation manual.
	CAUTION	This symbol shows that information is available such as the operating manual or installation manual.

### DANGER

- Before touching electric terminal parts, turn off power switch.
- When service panels are removed, live parts can be easily touched by accident.
- Never leave the unit unattended during installation or servicing when the service panel is removed.
- Do not touch water pipes during and immediately after operation as the pipes may be hot and could burn your hands. To avoid injury, give the piping time to return to normal temperature or be sure to wear protective gloves.
- Do not touch any switch with wet fingers. Touching a switch with wet fingers can cause electrical shock. Before touching electrical parts, turn off all applicable power to the unit.

## ⚠ WARNING

- Servicing shall only be performed as recommended by the equipment manufacturer. Maintenance and repair requiring the assistance of other skilled personnel shall be carried out under the supervision of the person competent in the use of flammable refrigerants.
- Tear apart and throw away plastic packaging bags so that children will not play with them. Children playing with plastic bags face danger.
- Safely dispose of packing materials such as nails and other metal or wood parts that could cause injuries.
- Ask your dealer or qualified personnel to perform installation work in accordance with this manual. Do not install the unit yourself. Improper installation could result in water leakage, electric shocks or fire.
- Be sure to use only specified accessories and parts for installation work. Failure to use specified parts may result in water leakage, electric shocks, fire, or the unit falling from its mount.
- Install the unit on a foundation that can withstand its weight. Insufficient physical strength may cause the equipment to fall and possible injury.
- Perform specified installation work with full consideration of strong wind, hurricanes, or earthquakes. Improper installation work may result in accidents due to equipment falling.
- Make certain that all electrical work is carried out by qualified personnel according to the local laws and regulations and this manual using a separate circuit. Insufficient capacity of the power supply circuit or improper electrical construction may lead to electric shocks or fire.
- Be sure to install a ground fault circuit interrupter according to local laws and regulations. Failure to install a ground fault circuit interrupter may cause electric shocks and fire.
- Make sure all wiring is secure. Use the specified wires and ensure that terminal connections or wires are protected from water and other adverse external forces. Incomplete connection or affixing may cause a fire.
- When wiring the power supply, form the wires so that the front panel can be securely fastened. If the front panel is not in place there could be overheating of the terminals, electric shocks or fire.
- After completing the installation work, check to make sure that there is no refrigerant leakage.
- Never directly touch any leaking refrigerant as it could cause severe frostbite. Do not touch the refrigerant pipes during and immediately after operation as the refrigerant pipes may be hot or cold, depending on the condition of the refrigerant flowing through the refrigerant piping, compressor and other refrigerant cycle parts. Burns or frostbite are possible if you touch the refrigerant pipes. To avoid injury, give the pipes time to return to normal temperature or, if you must touch them, be sure to wear protective gloves.
- Do not touch the internal parts (pump, backup heater, etc.) during and immediately after operation. Touching the internal parts can cause burns. To avoid injury, give the internal parts time to return to normal temperature or, if you must touch them, be sure to wear protective gloves.
- Do not use means to accelerate the defrosting process or to clean, other than those recommended by the manufacture.
- The appliance shall be stored in a room without continuously operating ignition sources (for example: open flames, an operating gas appliance or an operation electric heater.)
- Do not pierce or burn.
- Be aware that refrigerants may not contain an odour.



Caution: Risk of fire/  
flammable materials

## ⚠ CAUTION

- Ground the unit.
- Grounding resistance should be according to local laws and regulations.
- Do not connect the ground wire to gas or water pipes, lightning conductors or telephone ground wires. Incomplete grounding may cause electric shocks.
  - Gas pipes: Fire or an explosion might occur if the gas leaks.
  - Water pipes: Hard vinyl tubes are not effective grounds.
  - Lightning conductors or telephone ground wires: Electrical threshold may rise abnormally if struck by a lightning bolt.
- Install the power wire at least 3 feet (1 meter) away from televisions or radios to prevent interference or noise. (Depending on the radio waves, a distance of 3 feet (1 meter) may not be sufficient to eliminate the noise.)
- Do not wash the unit. This may cause electric shocks or fire. The appliance must be installed in accordance with national wiring regulations. If the supply cord is damaged, it must be replaced by the manufacturer, its service agent or similarly qualified persons in order to avoid a hazard.

- Do not install the unit in the following places:
  - Where there is mist of mineral oil, oil spray or vapors. Plastic parts may deteriorate, and cause them to come loose or water to leak.
  - Where corrosive gases (such as sulphurous acid gas) are produced. Where corrosion of copper pipes or soldered parts may cause refrigerant to leak.
  - Where there is machinery which emits electromagnetic waves. Electromagnetic waves can disturb the control system and cause equipment malfunction.
  - Where flammable gases may leak, where carbon fiber or ignitable dust is suspended in the air or where volatile flammables such as paint thinner or gasoline are handled. These types of gases might cause a fire.
  - Where the air contains high levels of salt such as near the ocean.
  - Where voltage fluctuates a lot, such as in factories.
  - In vehicles or vessels.
  - Where acidic or alkaline vapors are present.
- Children should not play with the unit. Cleaning and user maintenance should not be done by children without supervision. Children should be supervised to ensure that they do not play with the appliance.
- This appliance is intended to be used by expert or trained users in shops, in light industry and on farms, or for commercial use by lay persons
- If the supply cord is damaged, it must be replaced by the manufacturer or its service agent or a similarly qualified person in order to avoid a hazard.
- DISPOSAL: Do not dispose this product as unsorted municipal waste. Collection of such waste separately for special treatment is necessary. Do not dispose of electrical appliances as municipal waste, use separate collection facilities. Contact your local government for information regarding the collection systems available. If electrical appliances are disposed of in landfills or dumps, hazardous substance can leak into the groundwater and get into the food chain, damaging your health and well-being.
- The wiring must be performed by professional technicians in accordance with national wiring regulation and this circuit diagram. An all-pole disconnection device which has at least 3mm separation distance in all pole and a residual current device (RCD) with the rating not exceeding 30mA shall be incorporated in the fixed wiring according to the national rule.
- Confirm the safety of the installation area (walls, floors, etc.) without hidden dangers such as water, electricity, and gas. Before wiring/pipes.
- Before installation, check whether the user's power supply meets the electrical installation requirements of unit (including reliable grounding, leakage, and wire diameter electrical load, etc.). If the electrical installation requirements of the product are not met, the installation of the product is prohibited until the product is rectified.
- When installing multiple air conditioners in a centralized manner, please confirm the load balance of the three-phase power supply, and multiple units are prevented from being assembled into the same phase of the three-phase power supply.
- Product installation should be fixed firmly, Take reinforcement measures, when necessary.

#### 💡 NOTE

- About Fluorinated Gasses
  - This air-conditioning unit contains fluorinated gasses. For specific information on the type of gas and the amount, please refer to the relevant label on the unit itself. Compliance with national gas regulations shall be observed.
  - Installation, service, maintenance and repair of this unit must be performed by a certified technician.
  - Product uninstallation and recycling must be performed by a certified technician.
  - If the system has a leak-detection system installed, it must be checked for leaks at least every 12 months. When the unit is checked for leaks, proper record-keeping of all checks is strongly recommended.

## 3 BEFORE INSTALLATION

### 3.1 Handling of the unit

The angle of inclination should not be more than 15° when carrying the unit in case of overturn of the unit.

1) Rolling handling: several rolling rods of the same size are placed under the base of the unit, and the length of each rod must be more than the outer frame of the base and suitable for balancing of the unit.

2) Lifting: each lifting rope (belt) should be able to bear 4 times the weight of the unit. Check the lifting hook and ensure that it is firmly attached to the unit. To avoid damages to the unit, a protective block made of wood, cloth or hard paper should be placed between the unit and rope when lifting, and its thickness should be 50mm or more. It is strictly forbidden to stand under the machine when it is hoisted.

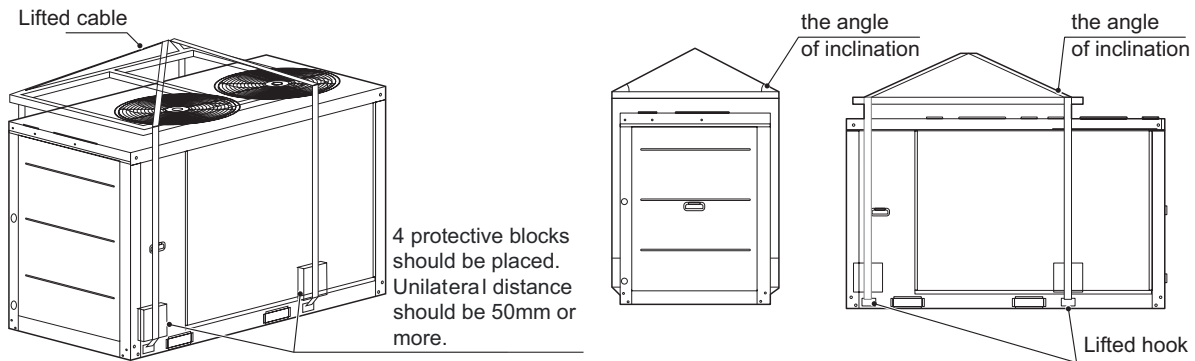

Fig. 3-1 lifting of the unit

## 4 IMPORTANT INFORMATION ON REFRIGERANT

This product contains fluorinated greenhouse gases covered by the Kyoto Protocol. Do not vent gases into the atmosphere.

Refrigerant type: R-32

GWP value: 675

GWP: global warming potential

The refrigerant quantity is indicated on the unit name plate

- Add the refrigerant

Amount of factory-charged refrigerant and tonnes CO<sub>2</sub> Equivalent is Table 4-1

Table 4-1

Model	Refrigerant (kg)	Tonnes CO <sub>2</sub> equivalent
KEM-30 DRS4	7.9	5.33
KEM-60 DRS4	14.0	9.45

## 5 SELECTION OF INSTALLATION SITE

- 1) Units can be installed on the ground or proper place on a roof, provided that sufficient ventilation can be guaranteed.
- 2) Do not install the unit in a scenario with requirements on noise and vibration.
- 3) When installing the unit, take measures to avoid exposure to direct sunlight, and keep the unit away from boiler pipeline and surroundings which might corrode the condenser coil and copper pipes.
- 4) If the unit is within the reach of unauthorized personnel, take protective measures for safety considerations, such as installing a fence. These measures can prevent man-caused or accidental injuries, and can also prevent the electrical parts in operation from being exposed when the main control box is opened.
- 5) Install the unit on a foundation at least 300 mm high above the ground, where the floor drain is provided, to ensure that water does not accumulate.
- 6) If installing the unit on the ground, put the steel base of the unit on the concrete foundation, which must be as deep as into the frozen soil layer. Ensure the installation foundation is separated from buildings, as the noises and vibration of the unit may adversely affect the latter. By means of the installation holes on the unit base, the unit can be fastened on the foundation reliably.
- 7) If the unit is installed on a roof, the roof must be strong enough to bear the weight of the unit and the weight of maintenance personnel. The unit can be placed on the concrete and groove-shaped steel frame, similar to the case when the unit is installed on the ground. The weight-bearing groove-shaped steel must match the installation holes of the shock absorber and is wide enough to accommodate the shock absorber.
- 8) For other special requirements for installation, please consult the building contractor, architectural designer or other professionals.

### NOTE

The selected installation site of the unit should facilitate connection of water pipes and wires, and be free from water inlet of oil fume, steam or other heat sources. Besides, the noise of the unit and cold and hot air should not influence the surrounding environment.

## 6 PRECAUTIONS ON INSTALLATION

### 6.1 Outline dimensional drawing

#### 6.1.1 KEM-30 DRS4

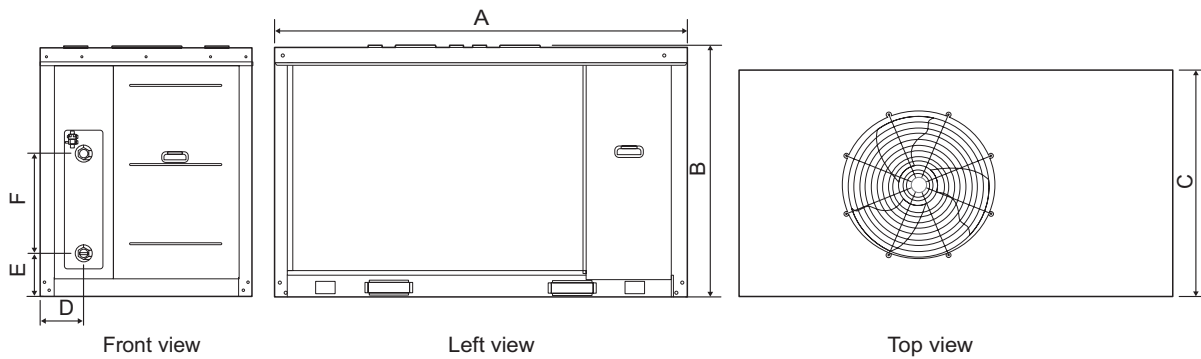

Fig. 6-1 Outline dimensional of KEM-30 DRS4

#### 6.1.2 KEM-60 DRS4

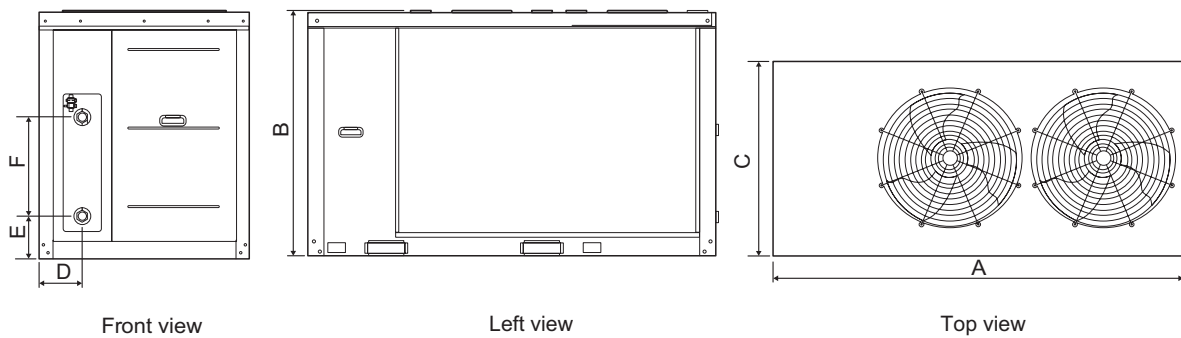

Fig. 6-2 Outline dimensional of KEM-60 DRS4

Table 6-1

Model	KEM-30 DRS4	KEM-60 DRS4
A	1870	2220
B	1000	1325
C	1175	1055
D	204	234
E	200	210
F	470	470

#### NOTE

After installing the spring damper, the total height of the unit will increase by 135mm or so.

## 6.2 Requirements of arrangement space of the unit

- 1) To ensure adequate airflow entering the condenser, the influence of descending airflow caused by the high-rise buildings around upon the unit should be taken into account when installing the unit.
- 2) If the unit is installed where the flowing speed of air is high, such as on the exposed roof, the measures including sunk fence and Persian blinds can be taken, to prevent the turbulent flow from disturbing the air entering the unit. If the unit needs to be provided with sunk fence, the height of the latter should not be more than that of the former; if Persian blinds are required, the total loss of static pressure should be less than the static pressure outside the fan. The space between the unit and sunk fence or Persian blinds should also meet the requirement.
- 3) If the unit needs to operate in winter, and the installation site may be covered by snow, the unit should be located higher than the snow surface, to ensure that air flows through the coils smoothly.

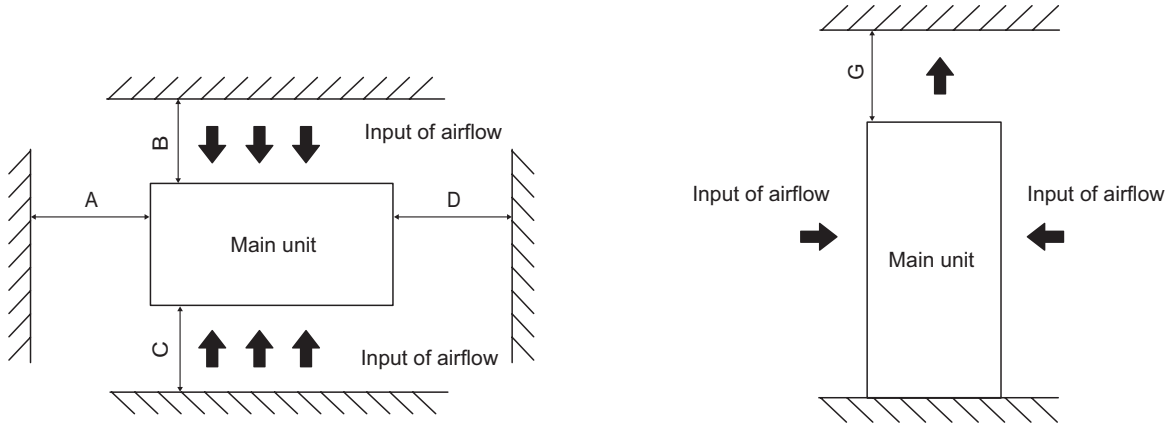

Fig. 6-3 single unit installation

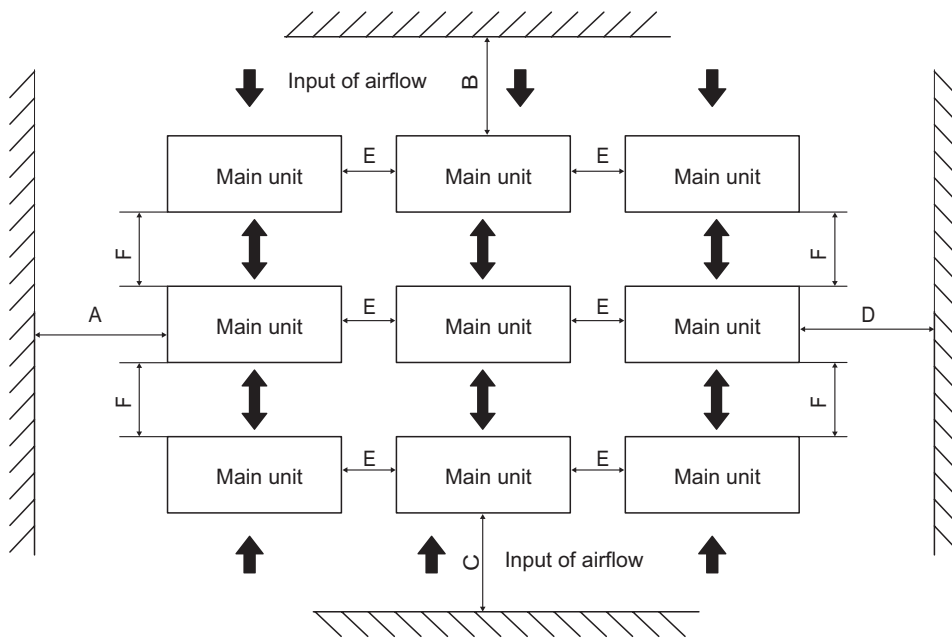

Fig. 6-4 multiple units installation

Table 6-2

Installation space (mm)			
A	≥800	E	≥800
B	≥2000	F	≥1100
C	≥2000	G	≥6000
D	≥800	/	/

## 6.3 Installation foundation

### 6.3.1 Base structure

Outdoor unit base structure design should take account of the following considerations:

- 1) A solid base prevents excess vibration and noise. Outdoor unit bases should be constructed on solid ground or on structures of sufficient strength to support the units' weight.
- 2) Bases should be at least 200mm high to provide sufficient access for installation of piping. Snow protection should also be considered for the base height.
- 3) Either steel or concrete bases may be suitable.
- 4) A typical concrete base design is shown in Fig. 6-5. A typical concrete specification is 1 part cement, 2 parts sand and 4 parts crushed stone with steel reinforcing bar. The edges of the base should be chamfered.
- 5) To ensure that all contact points are equally secure, bases should be completely level. Base design should ensure that the points on the units' bases designed for weight-bearing support are fully supported.

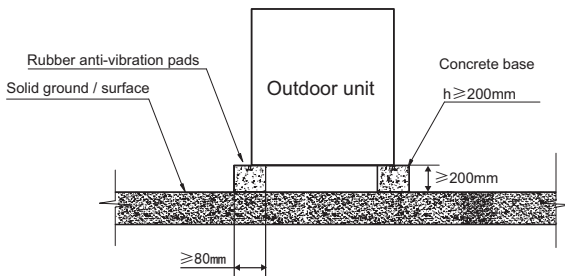

Fig. 6-5 Front view of base structure

### 6.3.2 Location drawing of installation foundation of the unit: (unit: mm)

- 1) If the unit is located so high that it is inconvenient for maintenance personnel to conduct maintenance, the suitable scaffold can be provided around the unit.
- 2) The scaffold must be able to bear the weight of maintenance personnel and maintenance facilities.
- 3) The bottom frame of the unit is not allowed to be embedded into the concrete of installation foundation.
- 4) A drainage ditch should be provided to allow drainage of condensate that may form on the heat exchangers when the units are running in heating mode. The drainage should ensure that condensate is directed away from roadways and footpaths, especially in locations where the climate is such that condensate may freeze.

(unit: mm)

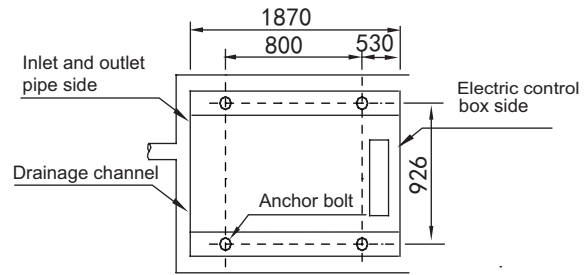

Fig. 6-6 Top view of schematic diagram of installation dimension of KEM-30 DRS4

(unit: mm)

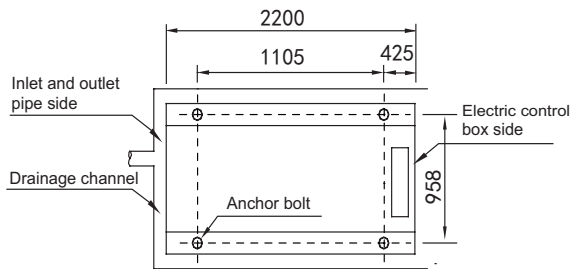

Fig. 6-7 Top view of schematic diagram of installation dimension of KEM-60 DRS4

## 6.4 Installation of damping devices

### 6.4.1 Damping devices must be provided between the unit and its foundation.

By means of the  $\Phi 15\text{mm}$  diameter installation holes on the steel frame of the unit base, the unit can be fastened on the foundation through the spring damper. See Fig.6-6, 6-7 (Schematic diagram of installation dimension of the unit) for details about center distance of the installation holes. The damper does not go with the unit, and the user can select the damper according to the relevant requirements. When the unit is installed on the high roof or the area sensitive to vibration, please consult the relevant persons before selecting the damper.

### 6.4.2 Installation steps of the damper

Step 1. Make sure that the flatness of the concrete foundation is within  $\pm 3\text{mm}$ , and then place the unit on the cushion block.

Step 2. Raise the unit to the height suitable for installation of the damping device.

Step 3. Remove the clamp nuts of the damper. Place the unit on the damper, and align the fixing bolt holes of the damper with the fixing holes on the unit base.

Step 4. Return the clamp nuts of the damper to the fixing holes on the unit base, and tighten them into the damper.

Step 5. Adjust the operational height of the damper base, and screw down the leveling bolts. Tighten the bolts by one circle to ensure equal height adjustment variance of the damper.

Step 6. The lock bolts can be tightened after the correct operational height is reached.

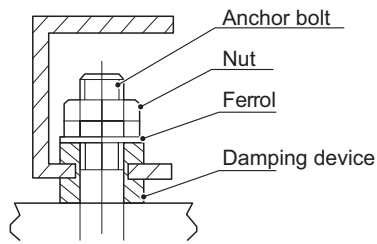

Fig. 6-8 Installation of the damper

## 6.5 Installation of device to prevent snow build-up and strong breeze

When installing an air-cooled heat pump chiller in a place with heavy snow, it is necessary to take snow protection measures to ensure trouble-free operation of the equipment. Otherwise, accumulated snow will block the air flow and may cause equipment problems.

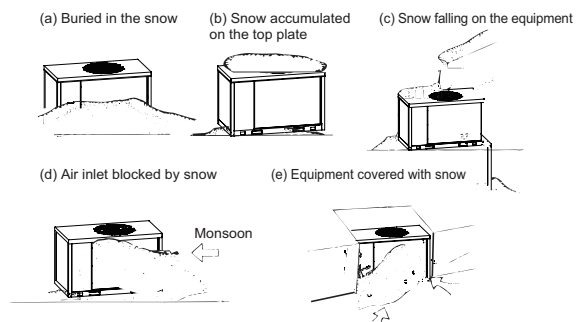

Fig. 6-9 Types of problems caused by snow

### 6.5.1 Measures used to prevent problems caused by snow

#### 1) Measures to prevent build-up of snow

The base height should be as least the same as the predicted snow depth in the local area.

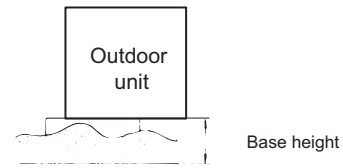

Fig. 6-10 Snow prevention base height

#### 2) Lightning protection and snow protection measures

Check the installation site thoroughly; do not install the equipment under awnings or trees or a place where snow is piled up.

### 6.5.2 Precautions for designing a snow cover

1) To ensure a sufficient air flow required by the air-cooled heat pump chiller, design a protective cover to make the dust resistance 1 mm H<sub>2</sub>O or less lower than the allowable external static pressure of air-cooled heat pump chiller.

2) The protective cover must be strong enough to withstand the snow weight and the pressure caused by strong wind and typhoon.

3) The protective cover must not cause short circuit of air discharge and suction

## 7 CONNECTION DRAWING OF PIPELINE SYSTEM

This is the water system of standard module.

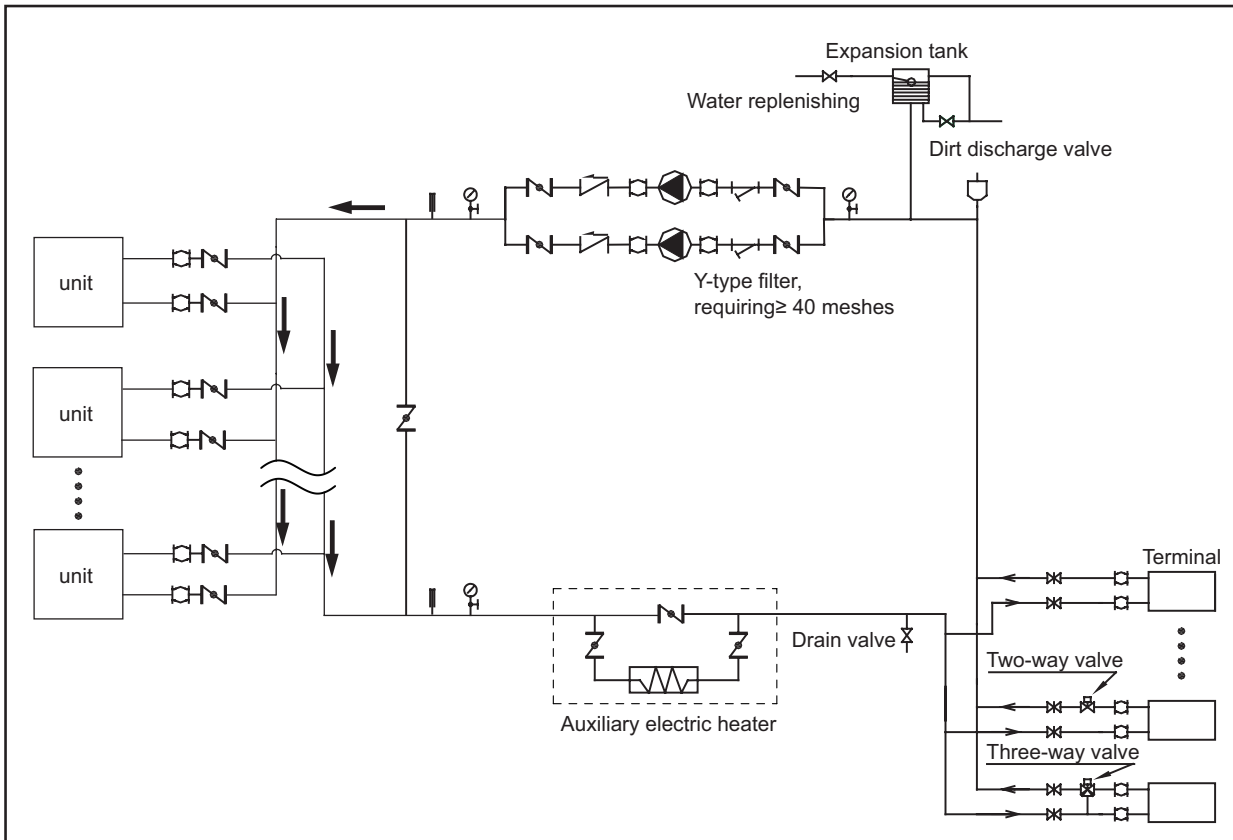

Symbol explanation				

Fig. 7-1 Connection drawing of pipeline system

### NOTE

- The ratio of the two - way valves on the terminal shall not exceed 50 percent.

## 8 OVERVIEW OF THE UNIT

### 8.1 Main parts of the unit

Table 8-1

NO.	NAME	NO.	NAME
1	Air outlet	6	Condenser
2	Top cover	7	Water inlet
3	Electric control box	8	Air inlet
4	Compressor	9	Water outlet
5	Evaporator	10	wire controller (It can be placed indoors)

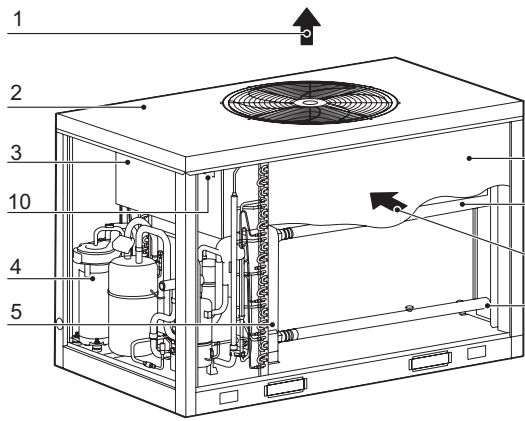

Fig. 8-1 Main parts of KEM-30 DRS4

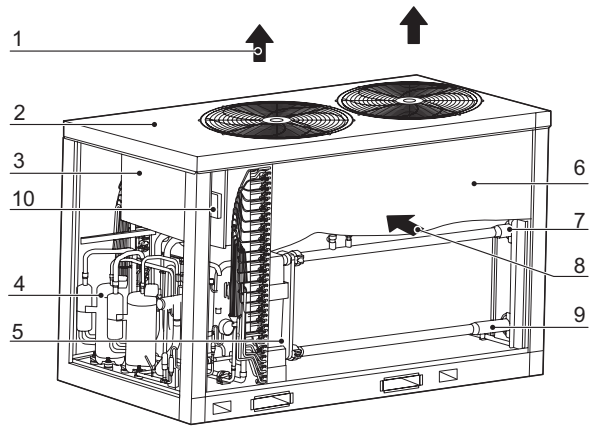

Fig. 8-2 Main parts of KEM-60 DRS4

## 8.2 Opening the unit

By means of a detachable service panel, the maintenance personnel can easily access the interior components of the unit.

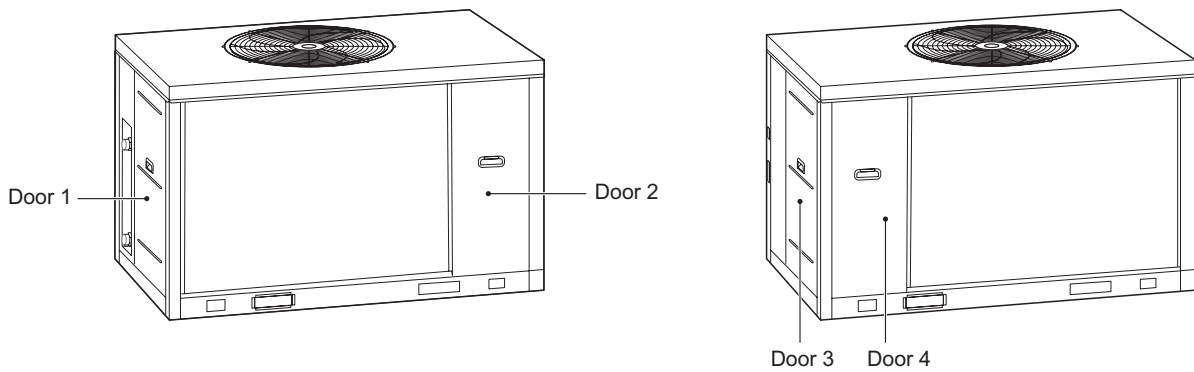

Fig. 8-3 Doors of KEM-30 DRS4

Door 1 give access to the compartment of water pipes and water side heat exchanger.

Door 2/3/4 give access to the hydraulic compartment and electrical parts.

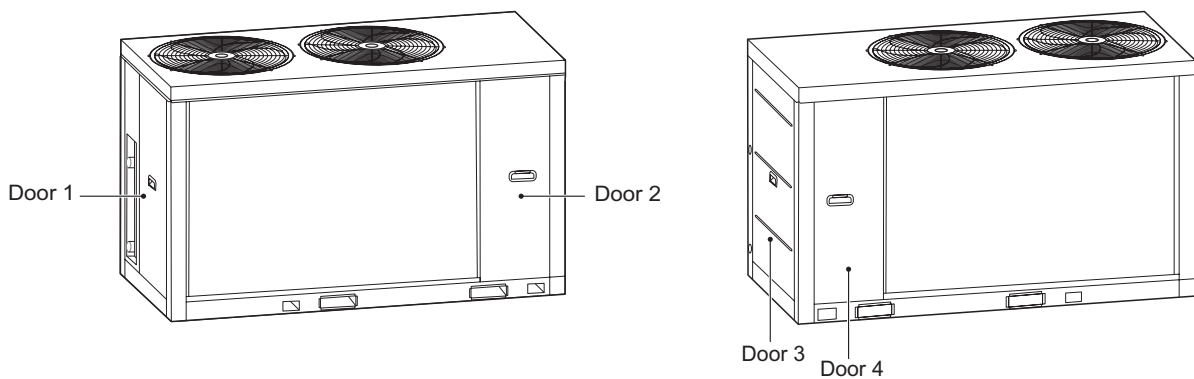

Fig. 8-4 Doors of KEM-60 DRS4

Door 1 give access to the compartment of water pipes, water side heat exchanger, accumulator and liquid-vapor separator.

Door 2/3/4 give access to the hydraulic compartment and electrical parts

## 8.3 System diagram

### 8.3.1 diagram of KEM-30 DRS4

Fig. 8-5 is the function diagram of the KEM-30 DRS4.

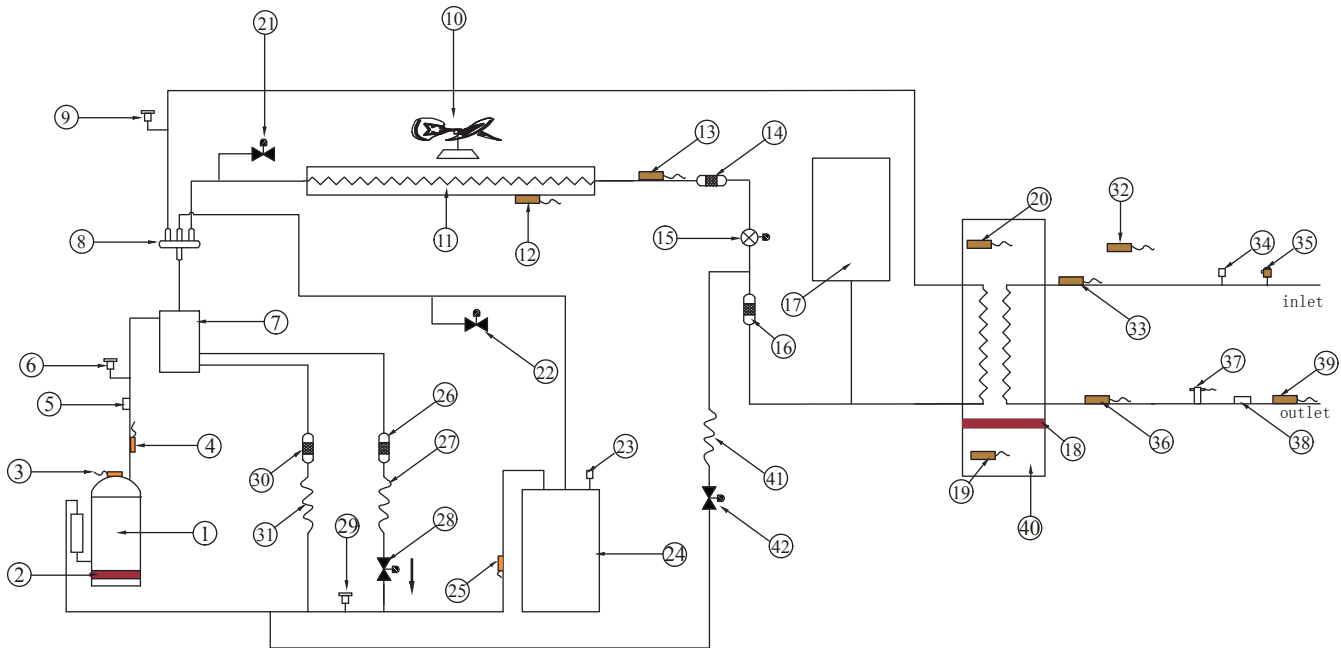

Fig. 8-5 KEM-30 DRS4 function diagram

Table 8-2

Legend			
1	DC inverter compressor	23	Safety valve
2	Crankcase heater	24	Gas-liquid separator
3	DC inverter compressor discharge temperature sensor 1	25	Suction temperature sensor
4	DC inverter compressor discharge temperature sensor 2	26	Filter
5	Discharge temperature control switch	27	Capillary
6	High pressure switch	28	Fast oil return solenoid valve
7	Oil separator	29	Low pressure switch
8	4-way-valve	30	Filter
9	System pressure sensor	31	Capillary
10	DC fan	32	Outdoor ambient temperature sensor
11	Condenser	33	Unit water inlet temperature sensor
12	Coil outlet temperature sensor	34	Safety valve
13	Coil final outlet temperature sensor	35	Air purge valve
14	Filter	36	Unit water outlet temperature sensor
15	Electronic expansion valve	37	Water flow switch
16	Filter	38	Manual water drain valve
17	High pressure tank	39	Total outlet water temperature sensor
18	Antifreeze heater of plate heat exchanger	40	Plate heat exchanger
19	Water side antifreeze temperature sensor 2	41	Capillary
20	Water side antifreeze temperature sensor 1	42	Electromagnetic valve
21	Stop valve	/	/
22	Stop valve	/	/

### 8.3.2 diagram of KEM-60 DRS4

Fig. 8-6 is the function diagram of the KEM-60 DRS4.

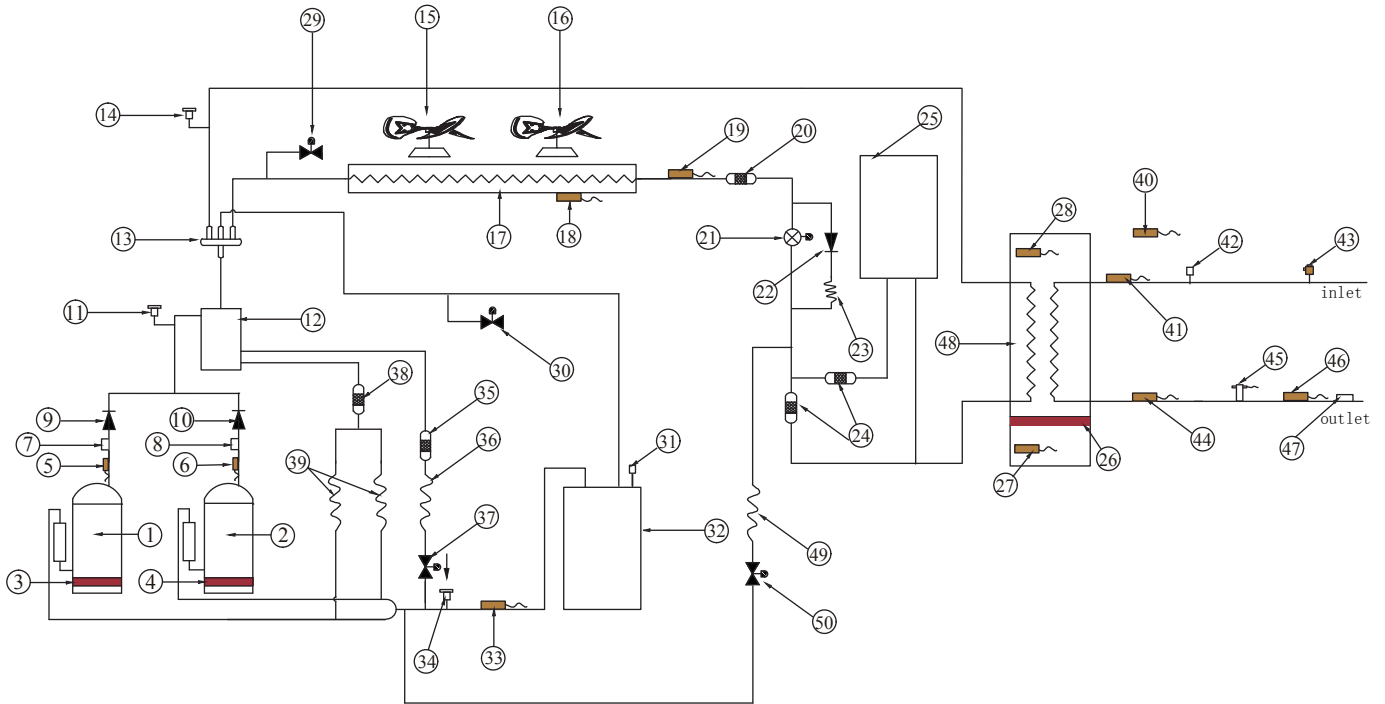

Fig. 8-6 KEM-60 DRS4 function diagram

Table 8-3

Legend			
1	Dc inverter compressor 1	27	Water side antifreeze temperature sensor 2
2	Dc inverter compressor 2	28	Water side antifreeze temperature sensor 1
3	Crankcase heater 1	29	Stop valve
4	Crankcase heater 2	30	Stop valve
5	Dc inverter compressor discharge temperature sensor 1	31	Safety valve
6	Dc inverter compressor discharge temperature sensor 2	32	Gas-liquid separator
7	Discharge temperature control switch 1	33	Suction temperature sensor
8	Discharge temperature control switch 2	34	Low pressure switch
9	One-way valve 1	35	Filter
10	One-way valve 2	36	Capillary
11	High pressure switch	37	Fast oil return solenoid valve
12	Oil separator	38	Filter
13	4-way valve	39	Capillary
14	System pressure sensor	40	Outdoor ambient temperature sensor
15	Dc fan 1	41	Unit water inlet temperature sensor
16	Dc fan 2	42	Safety valve
17	Condenser	43	Air purge valve
18	Coil outlet temperature sensor	44	Unit water outlet temperature sensor
19	Coil final outlet temperature sensor	45	Water flow switch
20	Filter	46	Total outlet water temperature sensor
21	Electronic expansion valve	47	Manual water drain valve
22	One-way valve 3	48	Plate heat exchanger
23	Capillary	49	Capillary
24	Filter	50	Electromagnetic valve
25	High pressure tank	/	/
26	Antifreeze heater of plate heat exchanger	/	/

## 8.4 Outdoor unit PCBs

### 8.4.1 MAIN PCB

1) Label descriptions are given in Table 8-7

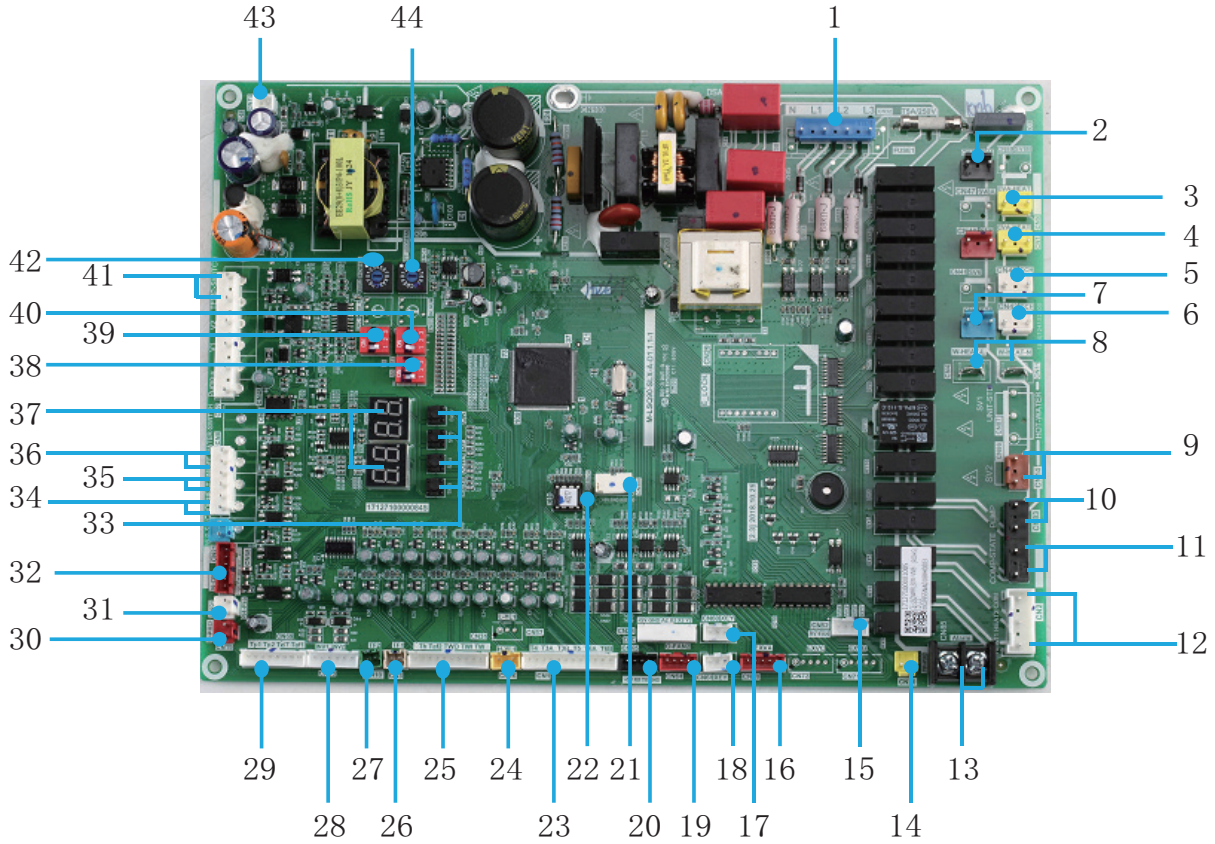

Fig. 8-7 Main PCB of KEM-30 DRS4 and KEM-60 DRS4

Table 8-4

NO.	Detail information
1	CN30: Input of three-phase four-wire power supply (fault code E1) Input of transformer, 220-240V AC current. (only valid for the main unit) Three phases A, B and C of power supply should exist 120° among them. If the conditions are not met, fault of phase sequence or phase lack may occur, and fault code will be displayed. When the power supply returns to normal condition, fault is removed. Attention: phase lace and phase dislocation of power supply are detected only in the early period after the power supply is connected, and they are not detected while the unit is in operation.
2	CN12: Quick return oil solenoid valve
3	CN5: EVA-HEAT, Water side heat exchanger heaters connection
4	CN13: EVA-HEAT, Electric of water side heat exchanger heaters connection
5	CN42: CCH, Crankcase heater
6	CN43: CCH, Crankcase heater
7	CN6: ST1, Four-way valve
8	CN4/CN11: W-HEAT, Electric heater of water flow switch
9	CN86: SV2, Spray cooling valve
10	CN83: Pump 1) After receiving start-up instruction, the pump will be started up instantly, and will maintain start-up state always in the process of operation. 2) In case of refrigerating or heating shutdown, the pump will be shut down 2 minutes after all modules stop operating. 3) In case of shutdown under the pump mode, the pump can be directly shut down.

NO.	Detail information
11	CN83: COMP-STATE, connect with an ac light to indicate the state of the compressor Attention: the control port value of the pump actually detected is ON/OFF but not 220-230V control power supply, so special attention should be paid when installing the light.
12	CN2: HEAT1. Pipeline Auxiliary Heater Attention: the control port value of the pump actually detected is ON/OFF but not 220-230V control power supply, so special attention should be paid when installing the pipeline auxiliary heater.
13	CN85: The alarm signal output of the unit (ON/OFF signal) Attention: the control port value of the pump actually detected is ON/OFF but not 220-230V control power supply, so special attention should be paid when installing the alarm signal output.
14	CN20: TP-PRO, Discharge temperature switch protection (protection code P0, prevent the compressor from over temperature 115°C)
15	CN52: Fan relay driver port.(Only for KEM-60 DRS4)
16	CN70: EXVA, System electronic expansion valve1.
17	CN60: Outdoor units communication or HMI communication port
18	CN61: Outdoor units communication or HMI communication port
19	CN64: Fan inverter module communication ports
20	CN65: Compressor inverter module communication ports
21	CN300: Program burn in port (WizPro200RS programming device).
22	IC10: EEPROM chip
23	CN1: temperature sensors input port. T4: outdoor ambient temperature sensor T3A/T3B: pipe temperature sensor of the condenser T5: water tank temperature sensor T6A: Refrigerant inlet temperature of EVI plate heat exchanger T6B: Refrigerant inlet temperature of EVI plate heat exchanger
24	CN16: System pressure sensor
25	CN31: Temperature sensors input port Th: System suction temperature sensor Taf2: Water side antifreeze temperature sensor Two: Unit water outlet temperature sensor Twi: Unit water inlet temperature sensor Tw: Total water outlet temperature sensor when several units are connected in parallel
26	CN3: Module 1 temperature sensor
27	CN10: Module 2 temperature sensor
28	CN15: Detection of current of the compressor system input port INV1: Detection of current of the compressor A INV2: Detection of current of the compressor B
29	CN69: Temperature sensors input port Tp1: DC inverter compressor 1 discharge temperature sensor Tp2: DC inverter compressor 2 discharge temperature sensor Tz7: coil final outlet temperature sensor Taf1: Water side antifreeze temperature
30	CN19: Low voltage protection switch. (Protection code P1)
31	CN91: Three-phase protector output switch. (Protection code E8)
32	CN58: Fan relay driver port.
33	SW3: Up button a) Select different menus when enter menu selection. b) For spot inspection in conditions. SW4: Down button a) Select different menus when enter menu selection. b) For spot inspection in conditions. SW5: Menu button Press to enter menu selection, short press to return to the previous menu. SW6: OK button Enter the submenu or confirm the function selected by short pressing.
34	CN8: Remote function of cool/heat signal
35	CN8: Remote function of on/off signal

NO.	Detail information
36	CN8: Water flow switch signal
37	Digital tube 1) In case of stand-by, the address of the module is displayed; 2) In case of normal operation, 10. is displayed (10 is followed by dot). 3) In case of fault or protection, fault code or protection code is displayed.
38	S5: Dip switch S5-3: Normal control, valid for S5-3 OFF (factory default). Remote control, valid for S5-3 ON.
39	S6: Dip switch S6-3: Anti-slow function is invalid, valid for S6-3 OFF (factory default). Ante-slow function is effective, valid for S6-3 ON.
40	S12: Dip switch S12-1: Valid for S12-1 ON (factory default). S12-2: Single water pump control, valid for S12-2 OFF (factory default). Multiple water pumps control, valid for S12-2 ON. S12-3: Normal cooling mode, valid for S12-3 OFF (factory default). Low temperature cooling, valid for S12-3 ON.
41	CN7: TEMP-SW, Target water temperature switching port.
42	ENC2: POWER DIP switch for capacity selection. (KEM-30 DRS4 defaults 0, KEM-60 DRS4 defaults 1)
43	CN74: The power supply port of the HMI. (DC9V)
44	ENC4: NET_ADDRESS DIP switch 0-F of outdoor unit network address is enabled, which represent address 0-15.

### CAUTION

- Faults

When the main unit suffers faults, the main unit stops operating, and all other units also stop running; When the subordinate unit suffers faults, only the unit stops operating, and other units are not affected.

- Protection

When the main unit is under protection, only the unit stops operating, and other units keep running;

When the subordinate unit is under protection, only the unit stops operating, and other units are not affected.

## 8.5 Electric wiring

### 8.5.1 Electric wiring

#### ⚠ CAUTION

- The air-conditioner should apply special power supply, whose voltage should conform to rated voltage.
- Wiring construction must be conducted by the professional technicians according to the labeling on the circuit diagram.
- The power wire and the grounding wire must be connected the suitable terminals.
- The power wire and the grounding wire must be fasten up by suitable tools.
- The terminals connected the power wire and the grounding wire must be fully fastened and regularly checked, in case to become flexible.
- Only use the electric components specified by our company, and require installation and technical services from the manufacturer or authorized dealer. If wiring connection fails to conform to electric installation norm, failure of the controller, electronic shock, and so on may be caused.
- The connected fixed wires must be equipped with full switching-off devices with at least 3mm contact separation.
- Set leakage protective devices according to the requirements of national technical standard about electric equipment.
- After completing all wiring construction, conduct careful check before connecting the power supply.
- Please carefully read the labels on the electric cabinet.
- The user's attempt to repair the controller is prohibited, since improper repair may cause electric shock, damages to the controller, and so on. If the user has any requirement of repair, please contact the maintenance center.
- The power cord type designation is H07RN-F.

### 8.5.2 KEM-30 DRS4 and KEM-60 DRS4

DIP switch, buttons and digital display positions of units.

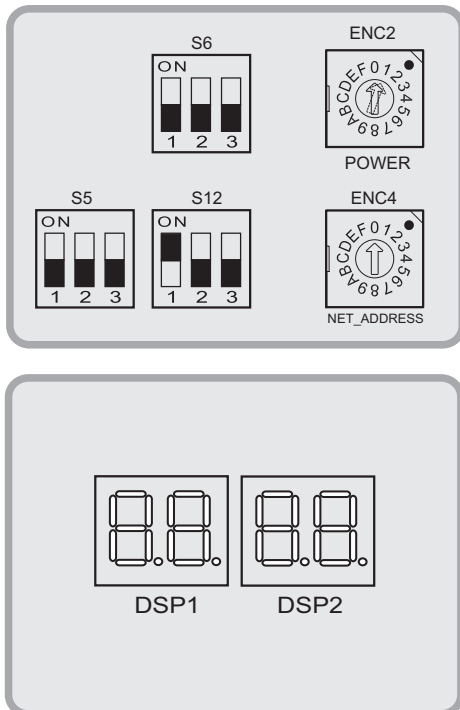

Fig. 8-8 Display positions

### 8.5.3 DIP switch instructions

Table 8-5 KEM-30 DRS4 and KEM-60 DRS4

ENC2		0/1	DIP switch for capacity selection (KEM-30 DRS4 defaults 0) (KEM-60 DRS4 defaults 1)
ENC4		0-F	0-F valid for unit address setting on the DIP switches 0 indicates the master unit and 1-F the auxiliary units (parallel connection) (0 by default)
S5-3		OFF	Normal control Valid for S5-3 OFF (factory default)
		ON	Remote control Valid for S5-3 ON
S6-3		OFF	Anti-slow function is invalid Valid for S6-3 OFF (factory default)
		ON	Anti-slow function is effective Valid for S6-3 ON
S12-1		ON	Valid for S12-1 ON (factory default)
S12-2		OFF	Single water pump control Valid for S12-2 OFF (factory default)
		ON	Multiple water pumps control Valid for S12-2 ON
S12-3		OFF	Normal cooling mode Valid for S12-3 OFF (factory default)
		ON	Low-temperature cooling mode Valid for S12-3 ON

### 8.5.4 Electrical wiring precautions

a. On-site wiring, parts and materials must comply with the local and national regulations as well as relevant national electrical standards.



Fig. 8-9-1 Electrical wiring precaution (a)

b. Copper core wires must be used

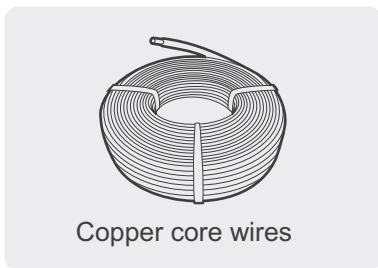

Fig. 8-9-2 Electrical wiring precaution (b)

c. It is advisable to use 3-core shielded cables for unit to minimize interference. Do not use the unshielded multicore conductor cables.



Fig. 8-9-3 Electrical wiring precaution (c)

d. Power wiring must be entrusted to professionals with electrician qualification.

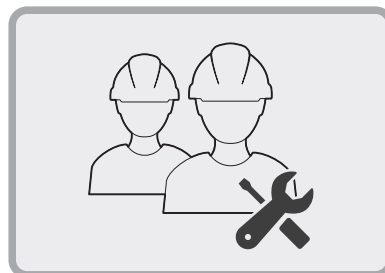

Fig. 8-9-4 Electrical wiring precaution (d)

### 8.5.5 Power supply specification

Table 8-6

Model	Item	Outdoor power supply			
		Power supply	Manual switch	Fuse	Wiring
KEM-30 DRS4		380-415V/3N~50Hz	50A	36A	10mm <sup>2</sup> X5 (<20m)
KEM-60 DRS4		380-415V/3N~50Hz	100A	63A	16mm <sup>2</sup> X5 (<20m)

#### NOTE

- See the table above for power wire diameter and length when the voltage drop at the power wiring point is within 2%. If the wire length exceeds the value specified in the table or the voltage drop is beyond the limit, the power wire diameter should be larger in accordance with the relevant regulations.

### 8.5.6 Requirements for power supply wiring

○ Correct

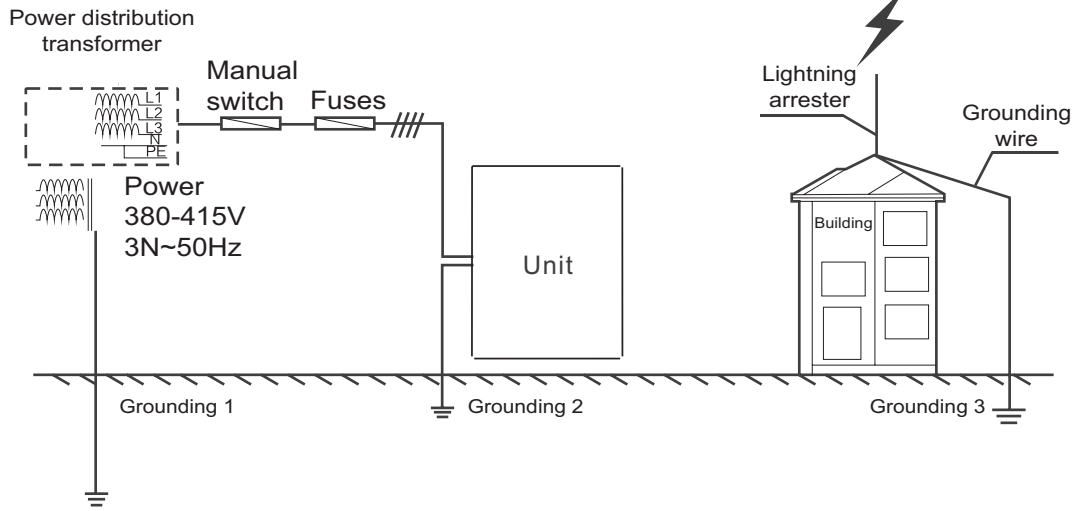

✗ Wrong

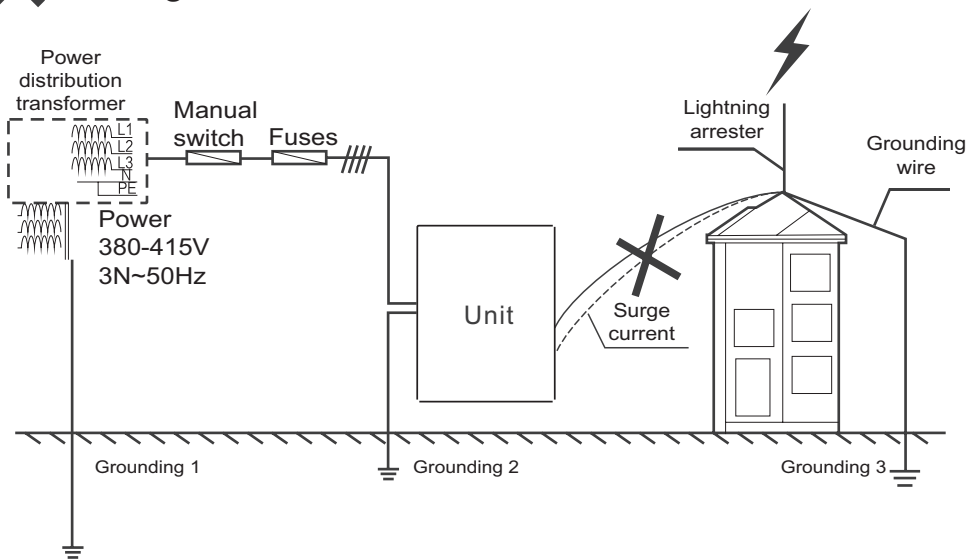

Fig. 8-10 Requirements of power supply wiring

💡 NOTE

- Do not connect the grounding wire of the lightning arrester to the unit shell. The grounding wire of the lightning arrester and the power supply grounding wire must be configured separately.

### 8.5.7 Requirements for power cord connection

○ Correct

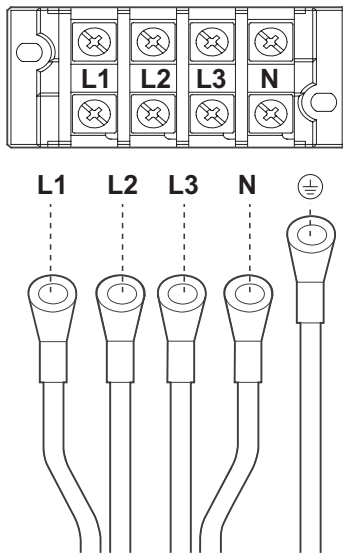

✗ Wrong

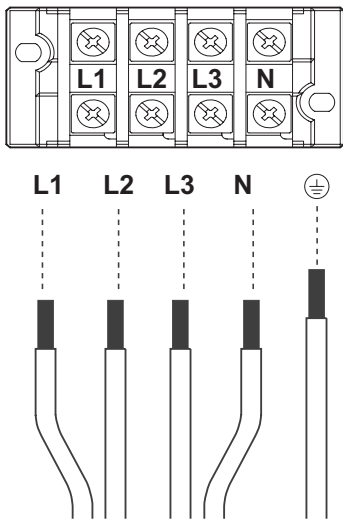

Fig. 8-11 Requirements for power cord connection

#### NOTE

Please use the round-type terminal with correct specifications to connect the power cord.

### 8.5.8 Function of terminals

As shown in the figure below, the unit communication signal wire is connected to the terminal block XT2 at 5 (X), 6 (Y) and 7 (E), and the wired controller signal wire is connected at 8 (X), 9 (Y) and 10 (E) inside the electric control box. For specific wiring, see chapter 8.5.13

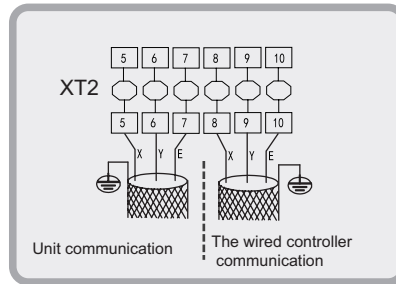

Fig. 8-12 Wiring of unit communication and the wired controller communication

When the water pump and auxiliary heater are added externally, a 3-phase contactor must be used for control. The model of contactor is subject to the power of water pump and heater power. The contactor coil is controlled by the main control board. See the figure below for coil wiring. For specific wiring, see chapter 8.5.13.

The user can connect an ac light to monitor the state of compressor. When the compressor is operating, the light will be powered on.

The wiring of water pump and pipeline auxiliary heater and ac light of the state of compressor is as follows.

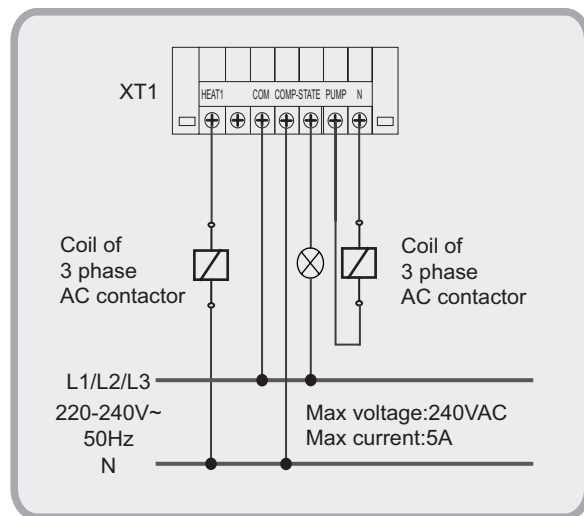

Fig. 8-13 Wiring of water pump and pipeline auxiliary heater and ac light of the state of compressor

### 8.5.9 Wiring of "ON/OFF" weak electric port

The remote function of "ON/OFF" must be set by DIP switch. The remote function of "ON/OFF" is effective when S5-3 is chosen ON, at the same time, the wired controller is out of control. Corresponding parallel connect the "ON/OFF" port of the main unit's electric control box, then, connect the "ON/OFF" signal (provide by user) to the "ON/OFF" port of main unit as follows. The remote function of "ON/OFF" must be DIP switch set. Wiring method: Shorting the terminal block XT2 at 15 and 24 inside the electric control box to enable the remote function of "ON/OFF".

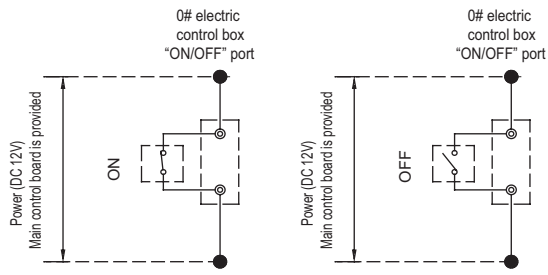

Fig. 8-14 Wiring of "ON/OFF" weak electric port

### 8.5.10 Wiring of "HEAT/COOL" weak electric port

The remote function of "HEAT/COOL" must be set by DIP switch. The remote function "HEAT/COOL" is effective when S5-3 is chosen ON, at the same time, the wire controller is out of control. Corresponding parallel connect the "HEAT/COOL" port of the main unit's electric control box, then, connect the "ON/OFF" signal (provide by user) to the "HEAT/COOL" port of main unit as follows.

Wiring method: Shorting the terminal block XT2 at 14 and 23 inside the electric control box to enable the remote function of "HEAT/COOL".

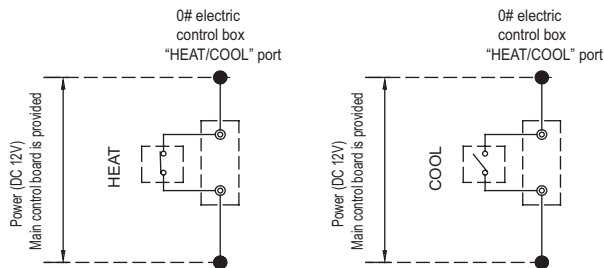

Fig. 8-15 Wiring of "HEAT/ COOL" weak electric port

### 8.5.11 Wiring of "ALARM" port

Connect the device provided by user to the "ALARM" ports of the module units as follows.

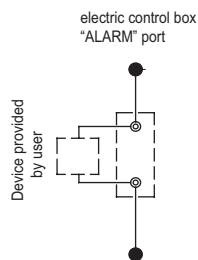

Fig. 8-16 Wiring of "ALARM" port

If the unit is operating unnormally, the ALARM port is closed, otherwise, the ALARM port is open.

The ALARM ports are on the main control board. See the wiring diagram for details.

### 8.5.12 Control system and installation precautions

a. Use only shielded wires as control wires. Any other type of wires may produce a signal interference that will cause the units to malfunction.



Fig. 8-17-1 Control system and installation precaution (a)

b. The shielding nets at both ends of the shielded wire must be grounded. Alternatively, the shielding nets of all shielded wires are interconnected and then connected to earth through or one metal plate.

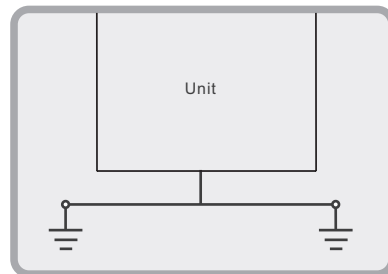

Fig. 8-17-2 Control system and installation precaution (b)

Do not bind the control wire, refrigerant piping and power cord together. When the power cord and control wire are laid parallel, they should be kept at a distance of more than 300 mm to prevent signal source interference.

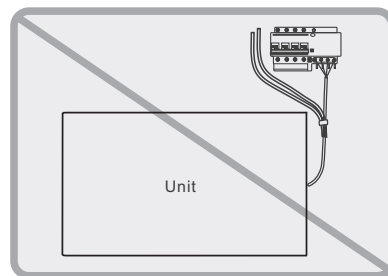

Fig. 8-17-3 Control system and installation precaution (c)

d. Pay attention to the polarity of the control wire when conducting wiring operations.

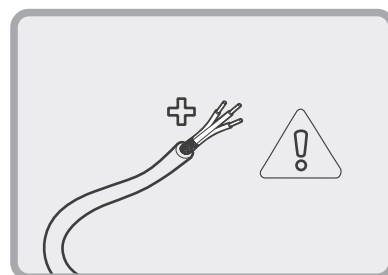

Fig. 8-17-4 Control system and installation precaution (d)

### 8.5.13 Wiring instances

If multiple units are connected in parallel, the user needs to set unit address on the DIP switches.

The DIP switch address is ENC4. With 0-F being valid, 0 indicates the main unit and 1-F indicate auxiliary units.

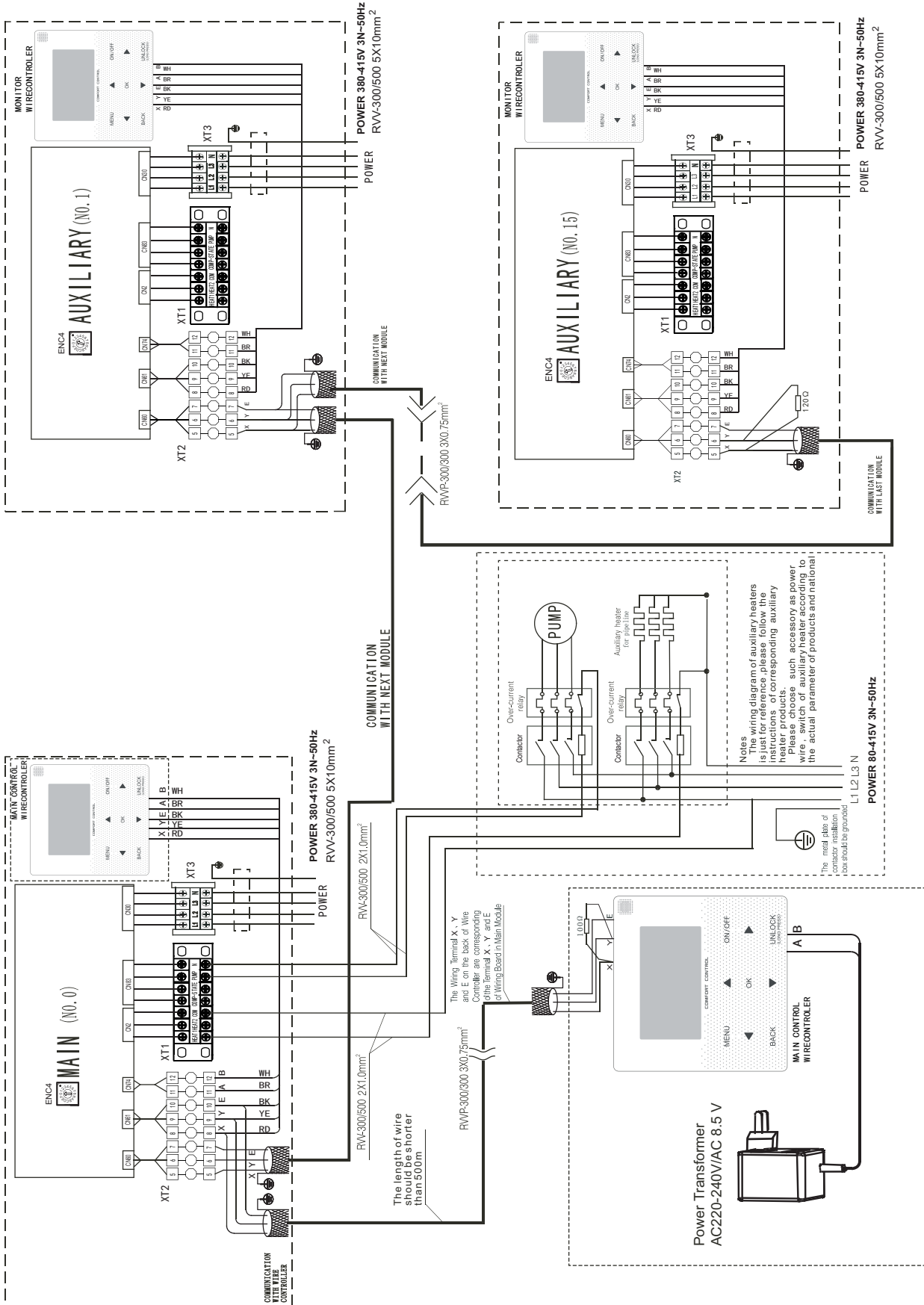

Fig. 8-18 Networking communication schematic of main unit and auxiliary unit for KEM-30 DRS4

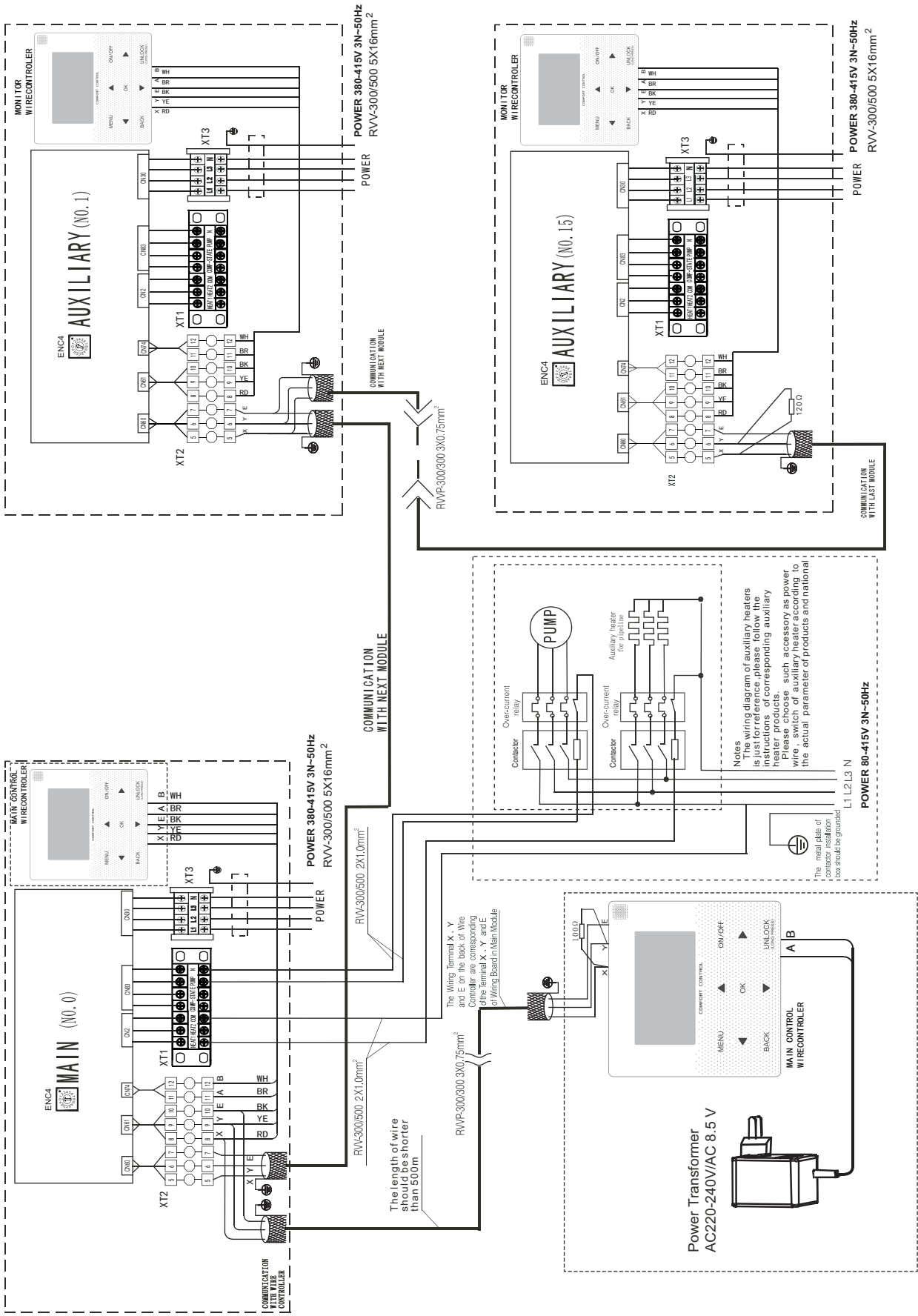

Fig. 8-19 Networking communication schematic of main unit and auxiliary unit for KEM-60 DRS4

## NOTE

When the power cord is parallel to the signal wire, make sure that they are enclosed in respective conduits and are kept a reasonable wire spacing. (Distance between the power cord and signal wire: 300mm if below 10A, and 500mm if below 50A)

## CAUTION

In the case of multiple units connection, the HMI of KEM-30 DRS4 and KEM-60 DRS4 can be paralleled with in the same system. But, KEM-30 DRS4 and KEM-60 DRS4 can not be paralleled with KEM-30 DNS3 and KEM-60 DNS3

## 8.6 Water system installation

### 8.6.1 Basic requirements of connection of chilled water pipes

#### CAUTION

- After the unit is in place, chilled water pipes can be laid.
- The relevant installation regulations should be abided with when conducting connection of water pipes.
- The pipelines should be free of any impurity, and all chilled water pipes must conform to local rules and regulations of pipeline engineering.

Connection requirements of chilled water pipes

- a) All chilled water pipelines should be thoroughly flushed, to be free of any impurity, before the unit is operated. Any impurity should not be flushed to or into the heat exchanger.
- b) Water must enter the heat exchanger through the inlet; otherwise the performance of the unit will decline.
- c) The inlet pipe of the evaporator must be provided with a target flow controller, to realize flow-break protection for the unit. Both ends of the target flow controller must be supplied with horizontal straight pipe sections whose diameter is 5 times that of the inlet pipe. The target flow controller must be installed in strict accordance with "Installation & Regulation Guide for Target Flow Controller" (Fig.8-28, 8-29). The wires of the target flow controller should be led to the electric cabinet through shielded cable (see Electric Controlling Schematic Diagram for details). The working pressure of the target flow controller is 1.0MPa, and its interface is 1 inch in diameter. After the pipelines are installed, the target flow controller will be set properly according to the rated water flow of the unit.
- d) The pump installed in the water pipeline system should be equipped with starter. The pump will directly press water into the heat exchanger of the water system.

e) The pipes and their ports must be independently supported but should not be supported on the unit.

f) The pipes and their ports of the heat exchanger should be easy to disassemble for operation and cleaning, as well as inspection of port pipes of the evaporator.

g) The evaporator should be provided with a filter with more than 40 meshes per inch at site. The filter should be installed near to the inlet port as much as possible, and be under heat preservation.

h) The by-pass pipes and by-pass valves as shown in Fig.8-23 must be mounted for the heat exchanger, to facilitate cleaning of the outside system of water passage before the unit is adjusted. During maintenance, the water passage of the heat exchanger can be cut off without disturbing other heat exchangers.

i) The flexible ports should be adopted between the interface of the heat exchanger and on-site pipeline, to reduce transfer of vibration to the building.

j) To facilitate maintenance, the inlet and outlet pipes should be provided with thermometer or manometer. The unit is not equipped with pressure and temperature instruments, so they need to be purchased by the user.

k) All low positions of the water system should be provided with drainage ports, to drain water in the evaporator and the system completely; and all high positions should be supplied with discharge valves, to facilitate expelling air from the pipeline. The discharge valves and drainage ports should not be under heat preservation, to facilitate maintenance.

l) All possible water pipes in the system to be chilled should be under heat preservation, including inlet pipes and flanges of the heat exchanger.

m) The outdoor chilled water pipelines should be wrapped with an auxiliary heating belt for heat preservation, and the material of the auxiliary heat belt should be PE, EDPM, etc., with thickness of 20mm, to prevent the pipelines from freezing and thus cracking under low temperature. The power supply of the heating belt should be equipped with an independent fuse.

n) When the ambient temperature is lower than 2°C, and the unit will be not used for a long time, water inside the unit should be drained. If the unit is not drained in winter, its power supply should not be cut off, and the fan coils in the water system must be provided with three-way valves, to ensure smooth circulation of the water system when the anti-freezing pump is started up in winter.

o) The common outlet pipelines of combined units should be provided with mixing water temperature sensor.

#### WARNING

- For the water pipeline network including filters and heat exchangers, dreg or dirt may seriously damages the heat exchangers and water pipes.
- The installation persons or the users must ensure the quality of chilled water, and de-icing salt mixtures and air should be excluded from the water system, since they may oxidize and corrode steel parts inside the heat exchanger.

### 8.6.2 Connection mode of pipe

The water inlet and outlet pipes are installed and connected as shown in the following figures. KEM-30 DRS4 model uses screwed connection, while the KEM-60 DRS4 model uses hoop connection. For the specifications of the water pipes and screw thread, see the Table 8-7 below.

Table 8-7

Model	Pipe connection methods	Specifications of water pipe	Specifications of screw thread
KEM-30 DRS4	Screwed connection	DN40	Rc 1 1/4
KEM-60 DRS4	Hoop connection	DN50	/

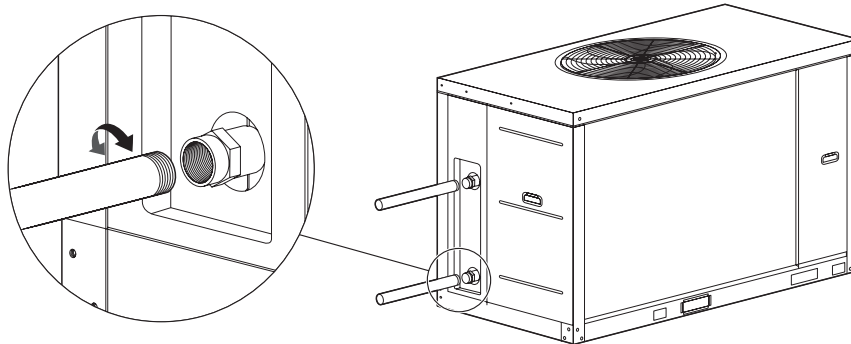

Fig.8-20 connection mode of KEM-30 DRS4 pipe

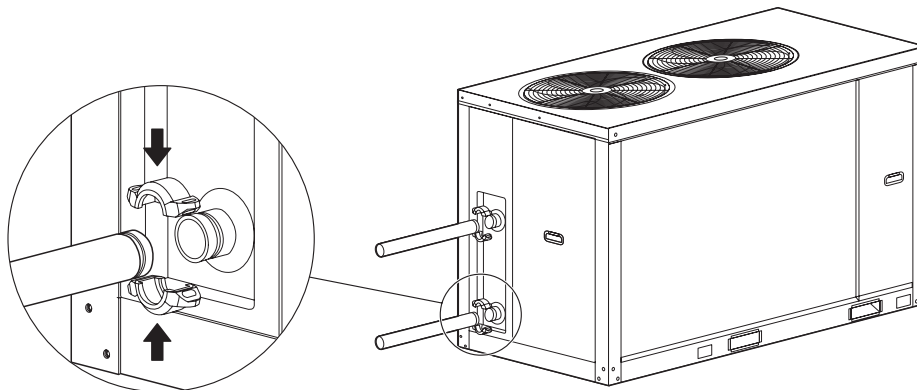

Fig.8-21 connection mode of KEM-60 DRS4 pipe

### 8.6.3 Design of the store tank in the system

kW is the unit for cooling capacity and L is the unit for G, water flow in the formula counting the minimum water flow.

Comfortable air conditioner  
 $G = \text{cooling capacity} \times 3.5L$

Process cooling  
 $G = \text{cooling capacity} \times 7.4L$

In certain occasion (especially in manufacture cooling process), for conforming the system water content requirement, it's necessary to mount a tank equipping with a cut-off baffle at the system to avoid water short-circuit, Please see the following schemes:

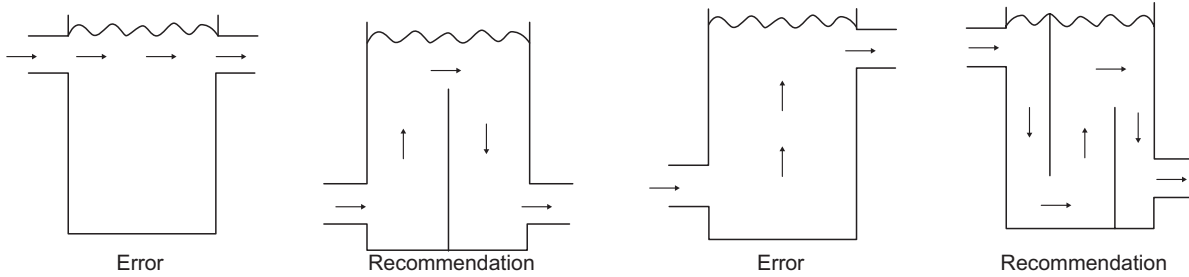

Fig.8-22 Design of the store tank

### 8.6.4 Minimum chilled water flow

The minimum chilled water flow is shown in the table 8-8

If the system flow is less than the minimum unit flow rate, the evaporator flow can be recirculated, as shown in the diagram.

For minimum chilled water flow rate

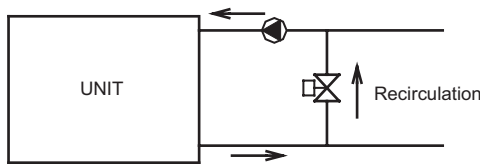

Fig. 8-23-1

### 8.6.5 Maximum chilled water flow

The maximum chilled water flow is limited by the permitted pressure drop in the evaporator. It is provided in the table 8-8

If the system flow is more than the maximum unit flow rate, bypass the evaporator as shown in the diagram to obtain a lower evaporator flow rate.

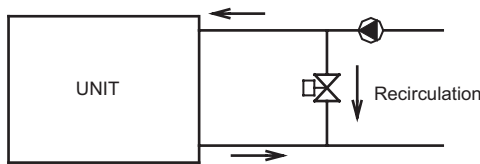

Fig. 8-23-2

### 8.6.6 Minimum and Maximum water flow

Table 8-8

Model	Item	Waterflow rate (m <sup>3</sup> /h)	
		Minimum	Maximum
KEM-30 DRS4		3.8	6.4
KEM-60 DRS4		8.0	13.0

### 8.6.7 Selection and installation of the pump

#### 1) Select the pump

a) Select the water-flow of the pump

The rated water-flow must no less than the unit rated water-flow; in terms of multi-connect the units, that water-flow must no less than total units' rated water-flow.

b) Select the lift of the pump.  $H=h1+h2+h3+h4$

H: The lift of the pump.

h1: Main unit water resistance.

h2: Pump water resistance.

h3: Water resistance of the longest water-loop distance, includes: pipe resistance, different valve's resistance, flexible pipe resistance, pipe elbow and three-way resistance, two-way resistance or three-way resistance, as well as filter resistance.

H4: the longest terminal resistance.

#### 2) Installation the pump

a) The pump should be installed at the water inlet pipe, both of which sides must mount the soft connectors for vibration-proof.

b) The backup pump for the system (recommended).

c) Units must with a main unit controls (Please see Fig. 8-18 for the controls wiring diagram).

### 8.6.8 Water quality

#### 1) Water quality control

When industrial water is used as chilled water, little furring may occur; however, well water or river water, used as chilled water, may cause much sediment, such as furring, sand, and so on.

Therefore, well water or river water must be filtered and softened in softening water equipment before flowing into chilled water system. If sand and clay settle in the evaporator, circulation of chilled water may be blocked, and thus leading to freezing accidents; if hardness of chilled water is too high, furring may occur easily, and the devices may be corroded. Therefore, the quality of chilled water should be analyzed before being used, such as PH value, conductivity, concentration of chloride ion, concentration of sulfide ion, and so on.

## 2) Applicable standard of water quality for the unit

Table 8-9

PH value	6.8~8.0	Sulfate	<50ppm
Total hardness	<70ppm	Silicon	<30ppm
Conductivity	<200 $\mu$ V/cm (25°C)	Iron content	<0.3ppm
Sulfide ion	No	Sodium ion	No requirement
Chloride ion	<50ppm	Calcium ion	<50ppm
Ammonia ion	No	/	/

## 8.6.9 Installation of multi-module water system pipeline

Multi-module combination installation involves special design of the unit, so relevant explanation is given as follows.

### 1) Installation mode of multi-module combination water system pipeline

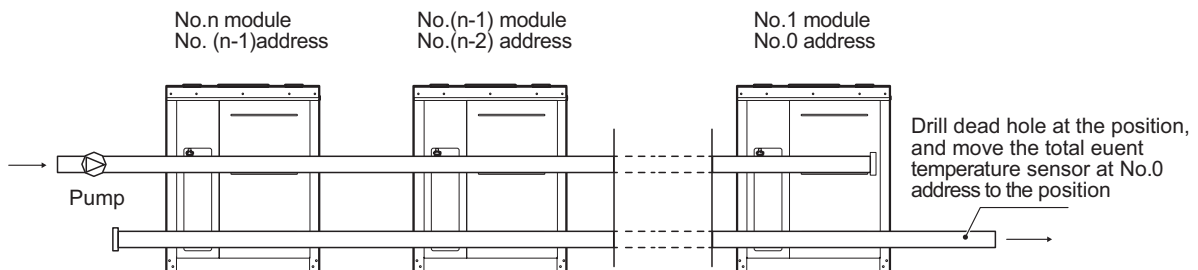

Fig.8-24 Installation of multi-module (no more than 16 modules)

### 2) Table of diameter parameters of main inlet and outlet pipes

Table 8-10

Cooling capacity	Total inlet and outlet water pipe inside nominal diameter
$15 \leq Q \leq 30$	DN40
$30 < Q \leq 90$	DN50
$90 < Q \leq 130$	DN65
$130 < Q \leq 210$	DN80
$210 < Q \leq 325$	DN100
$325 < Q \leq 510$	DN125
$510 < Q \leq 740$	DN150
$740 < Q \leq 1300$	DN200
$1300 < Q \leq 2080$	DN250

### ⚠ CAUTION

- Please pay attention to the following items when installing multiple modules:
  - Each module corresponds to an address code which cannot be repeated.
  - Main water outlet temperature sensing bulb, target flow controller and auxiliary electric heater are under control of the main module.
  - One wired controller and one target flow controller are required and connected on the main module.
  - The unit can be started up through the wired controller only after all addresses are set and the aforementioned items are determined. The wired controller is  $\leq 500$ m away from the outdoor unit.

## 8.6.10 Installation of single or multiple water pumps

### 1) DIP switch

The choice of DIP switch see Table 8-5 in detail when single or multiple water pumps are installed for KEM-30 DRS4 and KEM-60 DRS4.

Pay attention to the following problems:

- If the DIP switch is inconsistent, and the error code is FP, the unit is not allowed to operate.
- Only the main unit has the water pump output signal when single water pump installed, auxiliary units has no water pump output signal.
- The water pump control signal is available for both the main unit and auxiliary units when multiple pumps installed.

### 2) Installation of water pipe system

#### a. Single water pump

Piping does not require a one-way valve when single water pump is installed, refer to figure as follow.

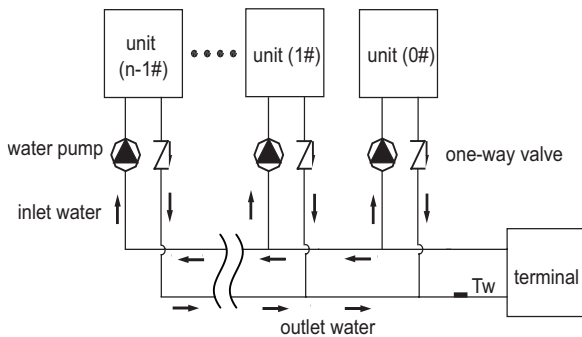

Fig.8-25 Installation of single water pump

#### b. Multiple water pumps

Each unit is required to install a one-way valve when multiple pumps are installed, refer to figure as follow.

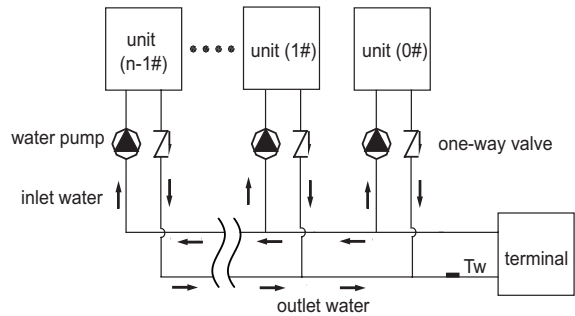

Fig.8-26 Installation of multiple water pump

### 3) Electric wiring

Only the main unit requires wiring when single water pump installed, auxiliary units do not require wiring. All of the main unit and auxiliary units require wiring when multiple water pumps installed. For specific wiring, see figure 8-18.

## 9 STRAT-UP AND CONFIGURATION

### 9.1 Initial start-up at low outdoor ambient temperatures

During initial start-up and when water temperature is low, it is important that the water is heated gradually. Failure to do so may result in concrete floors cracking due to rapid temperature change. Please contact the responsible cast concrete building contractor for further details.

To do so, the lowest water flow set temperature can be decreased to a value between 25°C and 35°C by adjusting the FOR SERVICEMAN.

Refer to "FOR SERVICEMAN/special function/preheating for floor"

### 9.2 Points for attention prior to trial run

- After the water system pipeline is flushed several times, please make sure that the purity of water meets the requirements; the system is re-filled with water and drained, and the pump is started up, then make sure that water flow and the pressure at the outlet meet the requirements.
- The unit is connected to the main power 12 hours before being started up, to supply power to the heating belt and pre-heat the compressor. Inadequate pre-heating may cause damages to the compressor.
- Setting of the wired controller. See details of the manual concerning setting contents of the controller, including such basic settings as refrigerating and heating mode, manual adjustment and automatic adjustment mode and pump mode. Under normal circumstances, the parameters are set around standard operating conditions for trial run, and extreme working conditions should be prevented as much as possible.
- Carefully adjust the target flow controller on the water system or the inlet stop valve of the unit, to make the water flow of the system be 90% of the water flow specified in troubleshooting table.

# 10 TEST RUN AND FINAL CHECK

## 10.1 Check item table after installation

Table 10-1

Checking item	Description	Yes	No
Whether installing site is meet for requirements	Units are fixed mounting on level base.		
	Ventilating space for heat exchanger at the air side is meeting for requirement		
	Maintenance space is meeting for requirement.		
	Noise and vibration is meeting for requirement.		
	Sun radiation and rain or snow proof measures are meeting for requirements.		
	External physical is meeting for requirement.		
Whether water system is meeting for requirements	Pipe diameter is meeting for requirement		
	The length of system is meeting for requirement		
	Water discharge is meeting for requirement		
	Water quality control is meeting for requirement		
	Flexible tube's interface is meeting for requirement		
	Pressure control is meeting for requirement		
	Thermal insulation is meeting for requirement		
	Wire capacity is meeting for requirement		
	Switch capacity is meeting for requirement		
	Fuse capacity is meeting for requirement		
	Voltage and frequency are meeting for requirement		
	Whether electric wiring system is meeting for requirements	Connecting tightly between wires	
Operation control device is meeting for requirement			
Safety device is meeting for requirement			
Chained control is meeting for requirement			
Phase sequence of power supply is meeting for requirement			

## 10.2 Trial run

- 1) Start up the controller and check whether the unit displays a fault code. If a fault occurs, remove the fault first, and start the unit according to the operating method in the "unit control instruction", after determining that there is no fault existing in the unit.
- 2) Conduct trial run for 30 min. When the influent and effluent temperature becomes stabilized, adjust the water flow to nominal value, to ensure normal operation of the unit.
- 3) After the unit is shut down, it should be put into operation 10 minutes later, to avoid frequent start-up of the unit. In the end, check whether the unit meets the requirements according to the contents in Table 11-1.

### CAUTION

- The unit can control start-up and shut-down of the unit, so when the water system is flushed, the operation of the pump should not be controlled by the unit.
- Do not start up the unit before draining the water system completely.
- The target flow controller must be installed correctly. The wires of the target flow controller must be connected according to electric control schematic diagram, or the faults caused by water breaking while the unit is in operation should be the user's responsibility.
- Do not re-start the unit within 10 min after the unit is shut down during trial run.
- When the unit is used frequently, do not cut off the power supply after the unit is shut down; otherwise the compressor cannot be heated, thus leading to its damages.
- If the unit is not in service for a long time, and the power supply needs to be cut off, the unit should be connected to the power supply 12 hours prior to re-starting of the unit, to pre-heat the compressor, the pump, the plate heat exchanger and the differential pressure value.

# 11 MAINTENANCE AND UPKEEP

## 11.1 Failure information and code

In case the unit runs under abnormal condition, failure protection code will display on both control panel and wired controller, and the indicator on the wired controller will flash with 1Hz. The display codes are shown in the following table:

Table11-1 KEM-30 DRS4 and KEM-60 DRS4

NO.	Code	Content	Note
1	E0	Main control parameter memory EPROM failure	Recovered upon failure recovery
2	E1	Phase sequence failure of main control board check	Recovered upon failure recovery
3	E2	Communication failure between master and the HMI	Recovered upon failure recovery
		Communication failure between master and slave	Recovered upon failure recovery
4	E3	Total water outlet temperature sensor failure (main unit valid)	Recovered upon failure recovery
5	E4	Unit water outlet temperature sensor failure	Recovered upon failure recovery
6	E5	1E5 condenser tube temperature sensor T3A failure	Recovered upon failure recovery
		2E5 condenser tube temperature sensor T3B failure	Recovered upon failure recovery
8	E7	Ambient temperature sensor failure	Recovered upon failure recovery
9	E8	Power supply phase sequence protector output error	Recovered upon failure recovery
10	E9	Water flow detection failure	If there is a failure recovery, the number of previous protections will be cleared
12	Eb	1Eb-->Taf1 cooling evaporator low-temperature antifreeze protection sensor failure	Recovered upon error recovery
		2Eb-->Taf2 cooling evaporator low-temperature antifreeze protection sensor failure	Recovered upon error recovery
13	EC	Slave unit module reduction	Recovered upon error recovery
14	Ed	1Ed-->A system discharge temperature sensor failure	Recovered upon error recovery
		2Ed-->B system discharge temperature sensor failure	Recovered upon error recovery
16	EF	Unit water return temperature sensor failure	Recovered upon error recovery
17	EH	System self-check failure alarm	Recovered upon error recovery
19	EP	Discharge temperature sensor failure alarm	Recovered upon error recovery
20	EU	Tz/7 Coil final outlet temperature sensor error	Recovered upon error recovery
21	P0	System high-pressure protection or discharge temperature protection	Occurs 3 times in 60 minutes and the error can be recovered by turning off the power supply only
22	P1	System low pressure protection	Occurs 3 times in 60 minutes and the error can be recovered by turning off the power supply only
23	P2	Tz/7 Coil final outlet temperature too high	Recovered upon error recovery
24	P3	T4 ambient temperature too high in cooling mode	Recovered upon error recovery
25	P4	System A current protection	Occurs 3 times in 60 minutes and the error can be recovered by turning off the power supply only
26	P5	System B current protection	Occurs 3 times in 60 minutes and the error can be recovered by turning off the power supply only
27	P6	Inverter module failure	Recovered upon error recovery
28	P7	High temperature protection of system condenser	Occurs 3 times in 60 minutes and the error can be recovered by turning off the power supply only
30	P9	Water inlet and outlet temperature difference protection	Recovered upon error recovery
32	Pb	Antifreeze protection in winter	Recovered upon error recovery
33	PC	Evaporator pressure too low in cooling	Recovered upon error recovery
35	PE	Cooling evaporator low temperature antifreeze protection	Recovered upon error recovery
37	PH	T4 ambient temperature too high in heating mode	Recovered upon error recovery

No.	Code	Content	Note
38	PL	Inverter module temperature Tfin too high temperature protection	Occurs 3 times in 100 minutes and the error can be recovered by turning off the power supply only
40	xPU	DC fan module protection	x=1 means Fan A,x=2 means Fan B Recovered upon error recovery
46	H5	Voltage too high or too low	Recovered by power off
50	xH9	Compressor inverter module is not matched	x=1 means compressor A, x=2 means compressor B
55	xHE	Not insert electronic expansion valve error	x=1 means valve A, x=2 means valve B
61	xF0	IPM module communication failure	x=1 means system A, x=2 means system B
63	F2	Superheat insufficient	Occurs 3 times in 240 minutes and the error can be recovered by turning off the power supply only
65	xF4	L0 or L1 protection occurs 3 times in 60 minutes	x=1 means system A, x=2 means system B
67	xF6	DC bus voltage error (PTC)	x=1 means system A, x=2 means system B
68	F7	Not insert electronic expansion valve	Recovered by power off
70	xF9	Inverter module temperature sensor error	x=1 means Tfin1, x=2 means Tfin2
72	Fb	Pressure sensor error	Recovered upon error recovery
74	Fd	Suction temperature sensor error	Recovered upon error recovery
76	xFF	DC fan failure	x=1 means fan A, x=2 means fan B
79	FP	DIP inconsistency of multiple water pumps	Recovered by power off
88	C7	If PL occurs 3 times,the system reports the C7 failure	Recovered by power off
101	L0	Compressor inverter module protection	Recovered upon error recovery
102	L1	DC bus low voltage protection	Recovered upon error recovery
103	L2	DC bus high voltage protection	Recovered upon error recovery
105	L4	MCE error	Recovered upon error recovery
106	L5	Zero speed protection	Recovered upon error recovery
108	L7	Phase sequence lost protection	Recovered upon error recovery
109	L8	Compressor frequency change over 15Hz	Recovered upon error recovery
110	L9	Compressor frequency difference 15Hz	Recovered upon error recovery
146	dF	Defrosting prompt	Flash when entering the defrosting

## 11.2 Digital display of main board

The data display area is divided into Up area and Down area, with two groups of two-digit half 7-segment digital display, respectively.

### a. Temperature display

Temperature display is used for displaying the total outlet water temperature of unit system, outlet water temperature, condenser pipe temperature T3A of system A, condenser pipe temperature T3B of system B, outdoor environmental temperature T4, anti-freezing temperature T6 and setting temperature Ts, with allowable data display scope  $-15^{\circ}\text{C}\sim 70^{\circ}\text{C}$ . If the temperature is higher than  $70^{\circ}\text{C}$ , it is displayed as  $70^{\circ}\text{C}$ . If there is no effective date, it displays “— —” and indication point °C is on.

### b. Current display

Current display is used for displaying Modular unit system A compressor current IA or system B compressor current IB, with allowable display scope 0A~99A. If it is higher than 99A, it is displayed as 99A. If there is no effective date, it displays “— —” and indication point A is on.

### c. Failure display

It is used for displaying the total failure warning date of unit or that of Modular unit, with failure display scope E0~EF, E indicating failure, 0~F indicating failure code. “E-” is displayed when there is no failure and indication point # is on at the same time.

### d. Protection display

It is used for displaying the total system protection data of unit or the system protection data of Modular unit, with protection display scope P0~PF, P indicating system protection, 0~F indicating protection code. “P-” is displayed when there is no failure.

### e. Unit number display

It is used for displaying the address number of the currently selected Modular unit, with display scope 0~15 and indication point # is on at the same time.

### f. Display of online unit number and startup unit number

They are used for displaying the total online Modular units of the whole unit system and the number of the Modular unit under running state, respectively, with display scope 0~16. Any time when the spot check page is entered to display or change Modular unit, it is needed to wait for the up-to-date data of the Modular unit received and selected by wired controller. Before receiving the data, the wired controller only displays “——” on the data display Down area, and the Up area displays the address number of the Modular unit. No page can be turned, which continues until the wired controller receives the communication data of this Modular unit.

## 11.3 Care and maintenance

### 1) Maintenance period

It's recommended that before cooling in summer and heating in winter every year, consult local air conditioner customer service center to check and maintain the unit, to prevent air conditioner errors which bring inconvenience to your life and work.

## 2) Maintenance of main parts

Close attention should be paid to the discharge and suction pressure during the running process. Find out reasons and eliminate the failure if abnormality is found.

Control and protect the equipment. See to it that no random adjustment be made on the set points on site.

Regularly check whether the electric connection is loose, and whether there is bad contact at the contact point caused by oxidation and debris etc., and take timely measures if necessary.

Frequently check the work voltage, current and phase balance.

Check the reliability of the electric elements in time. Ineffective and unreliable elements should be replaced in time.

## 11.4 Removing scale

After long-time operation, calcium oxide or other minerals will be settled in the heat transfer surface of the water-side heat exchanger. These substances will affect the heat transfer performance when there is too much scale in the heat transfer surface.

and sequentially cause that electricity consumption increases and the discharge pressure is too high (or suction pressure too low). Organic acids such as formic acid, citric acid and acetic acid may be used to clean the scale. But in no way should cleaning agent containing fluoroacetic acid or fluoride should be used as the water-side heat exchange is made from stainless steel and is easy to be eroded to cause refrigerant leakage. Pay attention to the following aspects during the cleaning and scale-removing process:

1) Water-side heat exchanger should be done by professionals. Please contact the local air-conditioner customer service center.

2) Clean the pipe and heat exchanger with clean water after cleaning agent is used. Conduct water treatment to prevent water system from being eroded or re-absorption of scale.

3) In case of using cleaning agent, adjust the density of the agent, cleaning time and temperature according to the scale settlement condition.

4) After pickling is completed, neutralization treatment needs to be done on the waste liquid. Contact relevant company for treating the treated waste liquid.

5) Protection equipments (such as goggles, gloves, mask and shoes) must be used during the cleaning process to avoid breathing in or contacting the agent as the cleaning agent and neutralization agent is corrosive to eyes, skins and nasal mucosa.

## 11.5 Winter shutdown

For shutdown in winter, the surface of the unit outside and inside should be cleaned and dried. Cover the unit to prevent dust. Open discharge water valve to discharge the stored water in the clean water system to prevent freezing accident (it is preferable to inject antifreezer in the pipe).

## 11.6 Replacing parts

Parts to be replaced should be the ones provided by our company.

Never replace any part with different part.

## 11.7 First startup after shutdown

The following preparations should be made for re-startup of unit after long-time shutdown:

- 1) Thoroughly check and clean unit.
- 2) Clean water pipe system.
- 3) Check pump, control valve and other equipments of water pipe system.
- 4) Fix connections of all wires.
- 5) It is a must to electrify the machine 12 hours before startup.

## 11.8 Refrigeration system

Determine whether refrigerant is needed by checking the value of suction and discharge pressure and check whether there is a leakage. Air tight test must be made if there is a leakage or parts of refrigerating system is to be replaced. Take different measures in the following two different conditions from refrigerant injection.

1) Total leakage of refrigerant. In case of such situation, leakage detection must be made on the pressurized nitrogen used for the system. If repair welding is needed, welding cannot be made until all the gas in the system is discharged. Before injecting refrigerant, the whole refrigeration system must be completely dry and of vacuum pumping.

Connect vacuum pumping pipe at the fluoride nozzle at low-pressure side.

Remove air from the system pipe with vacuum pump. The vacuum pumping lasts for above 3 hours. Confirm that the indication pressure in dial gauge is within the specified scope.

When the degree of vacuum is reached, inject refrigerant into the refrigeration system with refrigerant bottle. Appropriate amount of refrigerant for injection has been indicated on the nameplate and the table of main technical parameters. Refrigerant must be injected from the low pressure side of system.

The injection amount of refrigerant will be affected by the ambient temperature. If the required amount has not been reached but no more injection can be done, make the chilled water circulate and start up the unit for injection. Make the low pressure switch temporarily short circuit if necessary.

2) Refrigerant supplement. Connect refrigerant injection bottle on the fluoride nozzle at low-pressure side and connect pressure gauge at low pressure side.

Make chilled water circulate and start up unit, and make the low pressure control switch short circuit if necessary.

Slowly inject refrigerant into the system and check suction and discharge pressure.

### CAUTION

- Connection must be renewed after injection is completed.
- Never inject oxygen, acetylene or other flammable or poisonous gas to the refrigeration system at leakage detection and air tight test. Only pressurized nitrogen or refrigerant can be used.

## 11.9 Disassembling compressor

Follow the following procedures if compressor needs to be disassembled:

- 1) Cut off the power supply of unit.
- 2) Remove power source connection wire of compressor.
- 3) Remove suction and discharge pipes of compressor.
- 4) Remove fastening screw of compressor.
- 5) Move the compressor.

## 11.10 Auxiliary electric heater

When the ambient temperature is lower than 2°C, the heating efficiency decreases with the decline of the outdoor temperature. In order to make the air-cooled heat pump stably run in a relatively cold region and supplement some heat lost due to de-frosting. When the lowest ambient temperature in the user's region in winter is within 0°C~10°C, the user may consider to use auxiliary electric heater.

Please refer to relevant professionals for the power of auxiliary electric heater.

## 11.11 System antifreezing

In case of freezing at the water-side heat exchanger interval channel, severe damage may be caused, i.e. heat exchange may be broken and appears leakage. This damage of frost crack is not within the warranty scope, so attention must be paid to antifreezing.

1) If the unit that is shutdown for standby is placed in an environment where the outdoor temperature is lower than 0°C, the water in the water system should be drained.

2) Water pipe may be frozen when the chilled water target flow controller and anti-freezing temperature sensor become ineffective at running, therefore, the target flow controller must be connected in accordance with the connection diagram.

3) Frost crack may happen to water-side heat exchanger at maintenance when refrigerant is injected to the unit or is discharged for repair. Pipe freezing is likely to happen any time when the pressure of refrigerant is below 0.4Mpa. Therefore, the water in the heat exchanger must be kept flowing or be thoroughly discharged.

## 11.12 Replacement of safety valve

Replace the safety valve as follows:

- 1) Reclaim the refrigerant completely in the system. Doing so requires professional staff and equipment;
- 2) Note to protect the tank coating. Avoid damage to coating from external force or high temperature when removing and installing the safety valve;
- 3) Heat the sealant to screw off the safety valve. Note to protect the area where the screwing tool meets the tank body and avoid damages to the tank coating;
- 4) If tank coating is damaged, repaint the damaged area.

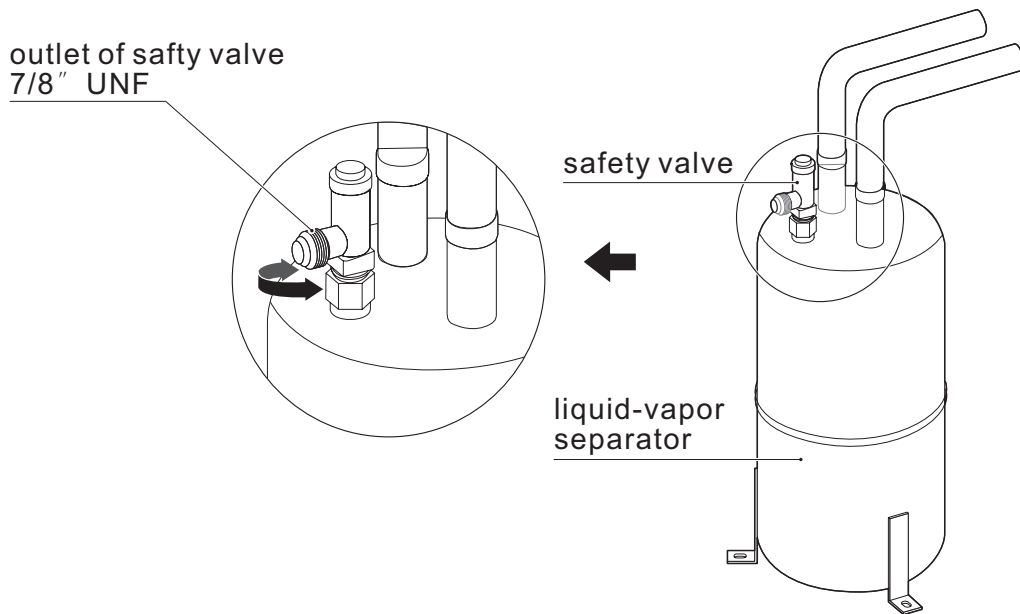

Fig.11-1 Replacement of safety valve

### ⚠ WARNING

- The air outlet of safety valve must be connected to the appropriate pipe, which can direct the leaking refrigerant to the appropriate place for discharge.
- Safety valve warranty period is 24 months. Under the specified conditions, if flexible sealing parts are used, the safety valve life expectancy is 24 to 36 months, if metal or PIFE sealing components are used, the average life expectancy is 36 to 48 months. Visual inspection is needed after that period, maintenance people should check the appearance of the valve body and the operating environment. If the valve body is not obvious corrosion, cracks, dirt, damage, then the valve can be used continually. Otherwise, please contact your supplier for spare part.

## 11.13 Information servicing

### 1) Checks to the area

Prior to beginning work on systems containing flammable refrigerants, safety checks are necessary to ensure that the risk of ignition is minimised. For repair to the refrigerating system, the following precautions shall be complied with prior to conducting work on the system.

### 2) Work procedure

Works shall be undertaken under a controlled procedure so as to minimise the risk of a flammable gas or vapour being present while the work is being performed.

### 3) General work area

All maintenance staff and others working in the local area shall be instructed on the nature of work being carried out. Work in confined spaces shall be avoided. The area around the work space shall be sectioned off. Ensure that the conditions within the area have been made safe by control of flammable material.

### 4) Checking for presence of refrigerant

The area shall be checked with an appropriate refrigerant detector prior to and during work, to ensure the technician is aware of potentially flammable atmospheres. Ensure that the leak detection equipment being used is suitable for use with flammable refrigerants, i.e. no sparking, adequately sealed or intrinsically safe.

### 5) Presence of fire extinguisher

If any hot work is to be conducted on the refrigeration equipment or any associated parts, appropriate fire extinguishing equipment shall be available to hand. Have a dry power or CO<sub>2</sub> fire extinguisher adjacent to the charging area.

### 6) No ignition sources

No person carrying out work in relation to a refrigeration system which involves exposing any pipe work that contains or has contained flammable refrigerant shall use any sources of ignition in such a manner that it may lead to the risk of fire or explosion. All possible ignition sources, including cigarette smoking, should be kept sufficiently far away from the site of installation, repairing, removing and disposal, during which flammable refrigerant can possibly be released to the surrounding space. Prior to work taking place, the area around the equipment is to be surveyed to make sure that there are no flammable hazards or ignition risks. NO SMOKING signs shall be displayed.

### 7) Ventilated area

Ensure that the area is in the open or that it is adequately ventilated before breaking into the system or conducting any hot work. A degree of ventilation shall continue during the period that the work is carried out. The ventilation should safely disperse any released refrigerant and preferably expel it externally into the atmosphere.

### 8) Checks to the refrigeration equipment

Where electrical components are being changed, they shall be fit for the purpose and to the correct specification. At all times the manufacturer's maintenance and service guidelines shall be followed. If in doubt consult the manufacturer's technical department for assistance. The following checks shall be applied to installations using flammable refrigerants:

- The charge size is in accordance with the room size within which the refrigerant containing parts are installed;
- The ventilation machinery and outlets are operating adequately and are not obstructed;
- If an indirect refrigerating circuit is being used, the secondary circuits shall be checked for the presence of refrigerant; marking to the equipment continues to be visible and legible.
- Marking and signs that are illegible shall be corrected;
- Refrigeration pipe or components are installed in a position where they are unlikely to be exposed to any substance which may corrode refrigerant containing components, unless the components are constructed of materials which are inherently resistant to being corroded or are suitably protected against being so corroded.

### 9) Checks to electrical devices

Repair and maintenance to electrical components shall include initial safety checks and component inspection procedures. If a fault exists that could compromise safety, then no electrical supply shall be connected to the circuit until it is satisfactorily dealt with. If the fault cannot be corrected immediately but it is necessary to continue operation, and adequate temporary solution shall be used. This shall be reported to the owner of the equipment so all parties are advised.

Initial safety checks shall include:

- of earth bonding.

### 10) Repairs to sealed components

a) During repairs to sealed components, all electrical supplies shall be disconnected from the equipment being worked upon prior to any removal of sealed covers, etc. If it is absolutely necessary to have an electrical supply to equipment during servicing, then a permanently operating form of leak detection shall be located at the most critical point to warn of a potentially hazardous situation.

b) Particular attention shall be paid to the following to ensure that by working on electrical components, the casing is not altered in such a way that the level of protection is affected. This shall include damage to cables, excessive number of connections, terminals not made to original specification, damage to seals, incorrect fitting of glands, etc.

- Ensure that apparatus is mounted securely.
- Ensure that seals or sealing materials have not degraded such that they no longer serve the purpose of preventing the ingress of flammable atmospheres. Replacement parts shall be in accordance with the manufacturer's specifications.

#### NOTE

The use of silicon sealant may inhibit the effectiveness of some types of leak detection equipment. Intrinsically safe components do not have to be isolated prior to working on them.

#### 11) Repair to intrinsically safe components

Do not apply any permanent inductive or capacitance loads to the circuit without ensuring that this will not exceed the permissible voltage and current permitted for the equipment in use. Intrinsically safe components are the only types that can be worked on while live in the presence of a flammable atmosphere. The test apparatus shall be at the correct rating. Replace components only with parts specified by the manufacturer. Other parts may result in the ignition of refrigerant in the atmosphere from a leak.

#### 12) Cabling

Check that cabling will not be subject to wear, corrosion, excessive pressure, vibration, sharp edges or any other adverse environmental effects. The check shall also take into account the effects of aging or continual vibration from sources such as compressors or fans.

#### 13) Detection of flammable refrigerants

Under no circumstances shall potential sources of ignition be used in the searching for or detection of refrigerant leaks. A halide

#### 14) Leak detection methods

The following leak detection methods are deemed acceptable for systems containing flammable refrigerants. Electronic leak detectors shall be used to detect flammable refrigerants, but the sensitivity may not be adequate, or may need re-calibration. (Detection equipment shall be calibrated in a refrigerant-free area.) Ensure that the detector is not a potential source of ignition and is suitable for the refrigerant. Leak detection equipment shall be set at a percentage of the LFL of the refrigerant and shall be calibrated to the refrigerant employed and the appropriate percentage of gas (25% maximum) is confirmed. Leak detection fluids are suitable for use with most refrigerants but the use of detergents containing chlorine shall be avoided as the chlorine may react with the refrigerant and corrode the copper pipe-work. If a leak is suspected, all naked flames shall be removed or extinguished. If a leakage of refrigerant is found which requires brazing, all of the refrigerant shall be recovered from the system, or isolated (by means of shut off valves) in a part of the system remote from the leak. Oxygen free nitrogen (OFN) shall then be purged through the system both before and during the brazing process.

#### 15) Removal and evacuation

When breaking into the refrigerant circuit to make repairs or for any other purpose conventional procedures shall be used. However, it is important that best practice is followed since flammability is a consideration. The following procedure shall be

- Remove refrigerant;
- Purge the circuit with inert gas;
- Evacuate;
- Purge again with inert gas;
- Open the circuit by cutting or brazing.

The refrigerant charge shall be recovered into the correct recovery cylinders. The system shall be flushed with OFN to render the unit safe. This process may need to be repeated several times.

Compressed air or oxygen shall not be used for this task.

Flushing shall be achieved by breaking the vacuum in the system with OFN and continuing to fill until the working pressure is achieved, then venting to atmosphere, and finally pulling down to a vacuum. This process shall be repeated until no refrigerant is within the system.

When the final OFN charge is used, the system shall be vented down to atmospheric pressure to enable work to take place. This operation is absolutely vital if brazing operations on the pipe-work are to take place.

Ensure that the outlet for the vacuum pump is not closed to any ignition sources and there is ventilation available.

#### 16) Charging procedures

In addition to conventional charging procedures, the following requirements shall be followed:

- Ensure that contamination of different refrigerants does not occur when using charging equipment. Hoses or lines shall be as short as possible to minimize the amount of refrigerant contained in them.
- Cylinders shall be kept upright.
- Ensure that the refrigeration system is earthed prior to charging the system with refrigerant.

- Ensure that the refrigeration system is earthed prior to charging the system with refrigerant.
- Label the system when charging is complete (if not already).
- Extreme care shall be taken not to overfill the refrigeration system.
- Prior to recharging the system it shall be pressure tested with OFN. The system shall be leak tested on completion of charging but prior to commissioning. A follow up leak test shall be carried out prior to leaving the site.

#### 17) Decommissioning

Before carrying out this procedure, it is essential that the technician is completely familiar with the equipment and all its detail. It is recommended good practice that all refrigerants are recovered safely. Prior to the task being carried out, an oil and refrigerant sample shall be taken.

In case analysis is required prior to re-use of reclaimed refrigerant. It is essential that electrical power is available before the task is commenced.

a) Become familiar with the equipment and its operation.

b) Isolate system electrically

c) Before attempting the procedure ensure that:

- Mechanical handling equipment is available, if required, for handling refrigerant cylinders;
- All personal protective equipment is available and being used correctly;
- The recovery process is supervised at all times by a competent person;
- Recovery equipment and cylinders conform to the appropriate standards.

d) Pump down refrigerant system, if possible.

e) If a vacuum is not possible, make a manifold so that refrigerant can be removed from various parts of the system.

f) Make sure that cylinder is situated on the scales before recovery takes place.

g) Start the recovery machine and operate in accordance with manufacturer's instructions.

h) Do not overfill cylinders. (No more than 80% volume liquid charge).

i) Do not exceed the maximum working pressure of the cylinder, even temporarily.

j) When the cylinders have been filled correctly and the process completed, make sure that the cylinders and the equipment are removed from site promptly and all isolation valves on the equipment are closed off.

k) Recovered refrigerant shall not be charged into another refrigeration system unless it has been cleaned and checked.

#### 18) Labelling

Equipment shall be labelled stating that it has been de-commissioned and emptied of refrigerant. The label shall be dated and signed. Ensure that there are labels on the equipment stating the equipment contains flammable refrigerant.

#### 19) Recovery

When removing refrigerant from a system, either for service or decommissioning, it is recommended good practice that all refrigerants are removed safely.

When transferring refrigerant into cylinders, ensure that only appropriate refrigerant recovery cylinders are employed. Ensure that the correct numbers of cylinders for holding the total system charge are available. All cylinders to be used are designated for the recovered refrigerant and labelled for that refrigerant (i.e special cylinders for the recovery of refrigerant). Cylinders shall be complete with pressure relief valve and associated shut-off valves in good working order.

Empty recovery cylinders are evacuated and, if possible, cooled before recovery occurs.

The recovery equipment shall be in good working order with a set of instructions concerning the equipment that is at hand and shall be suitable for the recovery of flammable refrigerants. In addition, a set of calibrated weighing scales shall be available and in good working order.

Hoses shall be complete with leak-free disconnect couplings and in good condition. Before using the recovery machine, check that it is in satisfactory working order, has been properly maintained and that any associated electrical components are sealed to prevent ignition in the event of a refrigerant release. Consult manufacturer if in doubt.

The recovered refrigerant shall be returned to the refrigerant supplier in the correct recovery cylinder, and the relevant Waste Transfer Note arranged. Do not mix refrigerants in recovery units and especially not in cylinders.

If compressors or compressor oils are to be removed, ensure that they have been evacuated to an acceptable level to make certain that flammable refrigerant does not remain within the lubricant. The evacuation process shall be carried out prior to returning the compressor to the suppliers. Only electric heating to the compressor body shall be employed to accelerate this process. When oil is drained from a system, it shall be carried out safely.

#### 20) Transportation, marking and storage for units

Transport of equipment containing flammable refrigerants Compliance with the transport regulations

Marking of equipment using signs Compliance with local regulations

Disposal of equipment using flammable refrigerants Compliance with national regulations

Storage of equipment/appliances

The storage of equipment should be in accordance with the manufacturer's instructions.

Storage of packed (unsold) equipment

Storage package protection should be constructed such that mechanical damage to the equipment inside the package will not cause a leak of the refrigerant charge.

The maximum number of pieces of equipment permitted to be stored together will be determined by local regulations.

## RECORD TABLE OF TEST RUN AND MAINTENANCE

Table 11-2

Model:	Customer name and address:
Code labeled on the unit:	Date:
<p>1. Check temperature of chilled water or hot water              Inlet ( ) Outlet ( )</p> <p>2. Check air temperature of air-side heat exchanger:              Inlet ( ) Outlet ( )</p> <p>3. Check refrigerant suction temperature and superheating temperature:              Refrigerant suction temperature: ( )( )( )( )( )              Superheating temperature: ( )( )( )( )( )</p> <p>4. Check pressure:              Discharge pressure: ( )( )( )( )( )              Suction pressure: ( )( )( )( )( )</p> <p>5. Check running current: ( )( )( )( )( )</p> <p>6. Whether unit has been through refrigerant leakage test? ( )( )( )( )( )</p> <p>7. Whether there is noise on all the panels of unit? ( )( )( )( )( )</p> <p>8. Check whether the main power source connection is correct. ( )( )( )( )( )</p>	

## RECORD TABLE OF ROUTINE RUNNING

Table 11-3

Model:	Weather:												
Date:	Operation time: Startup ( ) Shutdown ( )												
Outdoor temperature	Dry bulb	°C											
	Wet bulb	°C											
Indoor temperature		°C											
Compressor	High pressure	MPa											
	Low pressure	MPa											
	Voltage	V											
	Current	A											
Air temperature of air-side heat exchanger	Inlet (dry bulb)	°C											
	Outlet (dry bulb)	°C											
Temperature of chilled water or hot water	Inlet	°C											
	Outlet	°C											
Current of cooling water pump or hot water pump		A											
Note:													

## 12 APPLICABLE MODELS AND MAIN PARAMETERS

Table 12-1

Model		KEM-30 DRS4	KEM-60 DRS4
Cooling capacity	kW	27.5	55
Heating capacity	kW	32.0	62
Standard cooling input	kW	10.3	21.5
Cooling rated current	A	15.9	33.1
Standard heating input	kW	10.0	20.0
Heating rated current	A	15.4	30.8
Power supply	380-415V 3N~ 50Hz		
Operation control	Control of wired controller, auto startup, running state display, failure alert etc.		
Safety device	High or low pressure switch, freeze-proof device, water flow volume controller, Overcurrent device, power phase sequence device etc.		
Refrigerant	Type	R-32	
Water pipe system	Charging volume kg	7.9	14.0
	Waterflow volume m <sup>3</sup> /h	5.0	9.8
	Hydraulic resistance lose kPa	55	61
	Water side heat exchanger	Plate heat exchanger	
	Max. pressure MPa	1.0	
	Min. pressure MPa	0.05	
	Inlet and outlet pipe dia.	DN40	DN50
Air side heat exchanger	Type	Fin coil model	
	Air flow volume m <sup>3</sup> /h	12500	24000
Outline dimension N.W. of the unit	L mm	1870	2220
	W mm	1000	1055
	H mm	1175	1325
Net Weight	kg	300	480
Operation Weight	kg	310	490
Packing dimension	L × W × H mm	1910×1035×1370	2250×1090×1530

### 13 INFORMATION REQUIREMENTS

Table 13-1

Information requirements for comfort chillers								
Model (s):	KEM-30 DRS4							
Outdoor side heat exchanger of chiller:	Air to water							
Indoor side heat exchanger chiller:	Water							
Type:	Compressor driven vapour compression							
Driver of compressor:	Electric motor							
Item	Symbol	Value	Unit		Item	Symbol	Value	Unit
Rated cooling capacity	$P_{rated,c}$	28.95	kW		Seasonal space cooling energy efficiency	$\eta_{s,c}$	181.5	%
Declared cooling capacity for part load at given outdoor temperature $T_j$				Declared energy efficiency ratio for part load at given outdoor temperature $T_j$				
$T_j = + 35^\circ\text{C}$	$P_{dc}$	28.95	kW		$T_j = + 35^\circ\text{C}$	$EER_d$	2.65	--
$T_j = + 30^\circ\text{C}$	$P_{dc}$	21.11	kW		$T_j = + 30^\circ\text{C}$	$EER_d$	3.90	--
$T_j = + 25^\circ\text{C}$	$P_{dc}$	13.15	kW		$T_j = + 25^\circ\text{C}$	$EER_d$	5.35	--
$T_j = + 20^\circ\text{C}$	$P_{dc}$	6.58	kW		$T_j = + 20^\circ\text{C}$	$EER_d$	6.90	--
Degradation co-efficient for chillers (*)	$C_{dc}$	0.90	--					
Power consumption in modes other than 'active mode'								
Off mode	$P_{OFF}$	0.02	kW		Crankcase heater mode	$P_{CK}$	0	kW
Thermostat-off mode	$P_{TO}$	0.171	kW		Standby mode	$P_{SB}$	0.02	kW
Other items								
Capacity control	Variable				For air-to-water comfort chillers: air flow rate, outdoor measured	--	12500	$\text{m}^3/\text{h}$
Sound power level, indoors/outdoors	$L_{WA}$	-78	dB		For water / brine-to- water chillers: Rated brine or water flow rate, outdoor side heat exchanger	--	--	$\text{m}^3/\text{h}$
Emissions of nitrogen oxides (if applicable)	$\text{NO}_x$ (**)	--	mg/kWh input GCV					
GWP of the refrigerant	--	675	kg $\text{CO}_2$ eq (100 years)					
Standard rating conditions used:	Low temperature application							
(*) If $C_{dc}$ is not determined by measurement then the default degradation coefficient of chillers shall be 0.9.								
(**) From 26 September 2018.								

Table 13-2

Information requirements for comfort chillers							
Model (s):	KEM-60 DRS4						
Outdoor side heat exchanger of chiller:	Air to water						
Indoor side heat exchanger chiller:	Water						
Type:	Compressor driven vapour compression						
Driver of compressor:	Electric motor						
Item	Symbol	Value	Unit	Item	Symbol	Value	Unit
Rated cooling capacity	$P_{rated,c}$	55.1	kW	Seasonal space cooling energy efficiency	$\eta_{s,c}$	157.00	%
Declared cooling capacity for part load at given outdoor temperature $T_j$				Declared energy efficiency ratio for part load at given outdoor temperature $T_j$			
$T_j = + 35^\circ\text{C}$	$P_{dc}$	55.10	kW	$T_j = + 35^\circ\text{C}$	$EER_d$	2.64	--
$T_j = + 30^\circ\text{C}$	$P_{dc}$	38.72	kW	$T_j = + 30^\circ\text{C}$	$EER_d$	3.52	--
$T_j = + 25^\circ\text{C}$	$P_{dc}$	23.86	kW	$T_j = + 25^\circ\text{C}$	$EER_d$	4.50	--
$T_j = + 20^\circ\text{C}$	$P_{dc}$	11.72	kW	$T_j = + 20^\circ\text{C}$	$EER_d$	5.04	--
Degradation co-efficient for chillers (*)	$C_{dc}$	0.9	--				
Power consumption in modes other than 'active mode'							
Off mode	$P_{OFF}$	0.030	kW	Crankcase heater mode	$P_{CK}$	0	kW
Thermostat-off mode	$P_{TO}$	0.318	kW	Standby mode	$P_{SB}$	0.030	kW
Other items							
Capacity control	Variable			For air-to-water comfort chillers: air flow rate, outdoor measured	--	24000	m <sup>3</sup> /h
Sound power level, indoors/outdoors	$L_{WA}$	-/86	dB	For water / brine-to- water chillers: Rated brine or water flow rate, outdoor side heat exchanger	--	--	m <sup>3</sup> /h
Emissions of nitrogen oxides (if applicable)	$NO_x$ (**)	--	mg/ kWh input GCV				
GWP of the refrigerant	--	675	kg CO <sub>2</sub> eq (100 years)				
Standard rating conditions used:	Low temperature application						
(*) If $C_{dc}$ is not determined by measurement then the default degradation coefficient of chillers shall be 0,9.							
(**) From 26 September 2018.							

Table 13-3

Information requirements for heat pump space heaters and heat pump combination heaters							
Model (s):	KEM-30 DRS4						
Air-to-water heat pump:							[yes]
Water-to-water heat pump:							[yes/no]
Brine-to-water heat pump:							[yes/no]
Low-temperature heat pump:							[yes/no]
For low-temperature heat pumps, parameters shall be declared for low-temperature application. Otherwise, parameters shall be declared for medium-temperature application. Parameters shall be declared for average climate conditions.							
Item	Symbol	Value	Unit	Item	Symbol	Value	Unit
Rated heat output (3) at Tdesignh = -10 (-11) °C	Prated = Pdesignh	23.65	kW	Seasonal space heating energy efficiency	$\eta_s$	166.8	%
Seasonal coefficient of performance	SCOP	4.24	--	Active mode coef. of performance	SCOP <sub>on</sub>	--	--
				Net seasonal coef. of performance	SCOP <sub>net</sub>	--	--
T <sub>j</sub> = -7°C	Pdh	20.92	kW	T <sub>j</sub> = -7°C	COPd	2.86	--
T <sub>j</sub> = +2°C	Pdh	12.85	kW	T <sub>j</sub> = +2°C	COPd	3.98	--
T <sub>j</sub> = +7°C	Pdh	8.66	kW	T <sub>j</sub> = +7°C	COPd	5.75	--
T <sub>j</sub> = +12°C	Pdh	8.7	kW	T <sub>j</sub> = +12°C	COPd	6.82	--
T <sub>j</sub> = bivalent temperature	Pdh	20.92	kW	T <sub>j</sub> = bivalent temperature	COPd	2.86	--
T <sub>j</sub> = operation limit temperature	Pdh	23.57	kW	T <sub>j</sub> = operation limit temperature	COPd	2.57	--
For air-to-water heat pumps: T <sub>j</sub> = -15 °C (if TOL < -20 °C)	Pdh	--	kW	For air-to-water heat pumps: T <sub>j</sub> = -15 °C (if TOL < -20 °C)	COPd	--	--
Bivalent temperature (maximum +2°C)	Tbiv	-10	°C	For air-to-water HP: Operation limit temperature (maximum-7°C)	TOL	-10	°C
Cycling interval capacity for heating at T <sub>j</sub> = -7°C	Pcyc	--	kW	Heating water operating limit temperature	WTOL	--	°C
Degradation coefficient (4) at T = -7°C	Cdh	--	--	Cycling interval efficiency at T <sub>j</sub> = +7°C	COPcyc	--	--
Cycling interval capacity for heating at T <sub>j</sub> = +2°C	Pcyc	--	kW	Cycling interval capacity for heating at T = +12°C	COPcyc	--	--
Degradation coefficient (4) at T = +2°C	Cdh	--	--	Cycling interval efficiency at T <sub>j</sub> = +7°C	COPcyc	--	--
Cycling interval capacity for heating at T <sub>j</sub> = +7°C	Pcyc	--	kW	Cycling interval capacity for heating at T <sub>j</sub> = +12°C	COPcyc	--	--
Degradation coefficient (4) at T <sub>j</sub> = +7°C	Cdh	--	--	Supplementary heater (to be declared even if not provided in the unit)			
Cycling interval capacity for heating at T <sub>j</sub> = +12°C	Pcyc	--	kW	Rated heat output (3)	P <sub>sup</sub> = sup (T <sub>j</sub> )	x,x	kW
Degradation coefficient (4) at T <sub>j</sub> = +12°C	Cdh	--	--	Type of energy input			
Power consumption in modes other than active mode				Outdoor heat exchanger			
Off mode	P <sub>OFF</sub>	0.02	kW	For air-to-water HP: Rated air flow rate	Q <sub>airsource</sub>	12500	m <sup>3</sup> /h
Thermostat-off mode	P <sub>TO</sub>	0.440	kW	For water-to-water: Rated water flow rate	Q <sub>watersource</sub>	x	m <sup>3</sup> /h
Standby mode	P <sub>SB</sub>	0.02	kW	For brine-to-water: Rated brine flow rate	Q <sub>brinesource</sub>	x	m <sup>3</sup> /h
Crankcase heater mode	P <sub>CK</sub>	0	kW				
Other items							
Capacity control	Fixed/Variable	Variable					
Sound power level, indoors	L <sub>WA</sub>	x	dB (A)				
Sound power level, outdoors	L <sub>WA</sub>	78	dB (A)				
Contact details	Name and address of the manufacturer or its authorised representative.						
(1) For heat pump space heaters and heat pump combination heaters, the rated heat output Prated is equal to the design load for heating Pdesignh, and the rated heat output of a supplementary heater Psup is equal to the supplementary capacity for heating sup (T <sub>j</sub> ).							
(2) If Cdh is not determined by measurement then the default degradation coefficient is Cdh = 0.9.							

Table 13-4

Information requirements for heat pump space heaters and heat pump combination heaters								
Model (s):	KEM-60 DRS4							
Air-to-water heat pump:								[yes]
Water-to-water heat pump:								[yes/no]
Brine-to-water heat pump:								[yes/no]
Low-temperature heat pump:								[yes/no]
Equipped with a supplementary heater:								[yes/no]
Heat pump combination heater:								[yes/no]
For low-temperature heat pumps, parameters shall be declared for low-temperature application. Otherwise, parameters shall be declared for medium-temperature application. Parameters shall be declared for average climate conditions.								
Item	Symbol	Value	Unit	Item	Symbol	Value	Unit	
Rated heat output (3) at Tdesignh = -10 (-11) °C	Prated = Pdesignh	36.55	kW	Seasonal space heating energy efficiency	$\eta_s$	151.40	%	
Seasonal coefficient of performance	SCOP	3.86	--	Active mode coef. of performance	SCOP <sub>on</sub>	--	--	
				Net seasonal coef. of performance	SCOP <sub>net</sub>	--	--	
T <sub>j</sub> = -7°C	Pdh	32.33	kW	T <sub>j</sub> = -7°C	COPd	2.59	--	
T <sub>j</sub> = +2°C	Pdh	20.64	kW	T <sub>j</sub> = +2°C	COPd	3.76	--	
T <sub>j</sub> = +7°C	Pdh	12.89	kW	T <sub>j</sub> = +7°C	COPd	5.04	--	
T <sub>j</sub> = +12°C	Pdh	14.18	kW	T <sub>j</sub> = +12°C	COPd	6.02	--	
T <sub>j</sub> = bivalent temperature	Pdh	32.33	kW	T <sub>j</sub> = bivalent temperature	COPd	2.59	--	
T <sub>j</sub> = operation limit temperature	Pdh	35.42	kW	T <sub>j</sub> = operation limit temperature	COPd	2.28	--	
For air-to-water heat pumps: T <sub>j</sub> = -15 °C (if TOL < -20 °C)	Pdh	--	kW	For air-to-water heat pumps: T <sub>j</sub> = -15°C (if TOL < -20°C)	COPd	--	--	
Bivalent temperature (maximum +2°C)	Tbiv	-10	°C	For air-to-water HP: Operation limit temperature	TOL	-10	°C	
Cycling interval capacity for heating at T <sub>j</sub> = -7°C	Pcych	--	kW	(maximum -7°C)				
Degradation coefficient <sup>(4)</sup> at T = -7°C	Cdh	--	--	Heating water operating limit temperature	WTOL	--	°C	
Cycling interval capacity for heating at T <sub>j</sub> = +2°C	Pcych	--	kW	Cycling interval efficiency at T <sub>j</sub> = +7°C	COP <sub>pcyc</sub>	--	--	
Degradation coefficient <sup>(4)</sup> at T = +2°C	Cdh	--	--	Cycling interval capacity for heating at T <sub>j</sub> = +12°C	COP <sub>pcyc</sub>	--	--	
Cycling interval capacity for heating at T <sub>j</sub> = +7°C	Pcych	--	kW	Cycling interval efficiency at T <sub>j</sub> = +7°C	COP <sub>pcyc</sub>	--	--	
Degradation coefficient <sup>(4)</sup> at T <sub>j</sub> = +7°C	Cdh	--	--	Cycling interval capacity for heating at T <sub>j</sub> = +12°C	COP <sub>pcyc</sub>	--	--	
Cycling interval capacity for heating at T = +12°C	Pcych	--	kW					
Degradation coefficient <sup>(4)</sup> at T <sub>j</sub> = +12°C	Cdh	--	--					
Power consumption in modes other than active mode				Supplementary heater (to be declared even if not provided in the unit)				
Off mode	P <sub>OFF</sub>	0.035	kW	Rated heat output (3)	P <sub>sup = sup</sub>	--	kW	
Thermostat-off mode	P <sub>TO</sub>	0.409	kW	Type of energy input	(T <sub>j</sub> )			
Standby mode	P <sub>SB</sub>	0.035	kW	Outdoor heat exchanger				
Crankcase heater mode	P <sub>CK</sub>	0	kW	For air-to-water HP: Rated air flow rate	Q <sub>airsource</sub>	24000	m³/h	
Other items				For water-to-water: Rated water flow rate	Q <sub>watersource</sub>	x	m³/h	
Capacity control	Fixed/Variable	Variable		For brine-to-water: Rated brine flow rate	Q <sub>brinesource</sub>	x	m³/h	
Sound power level, indoors	L <sub>WA</sub>	x	dB (A)					
Sound power level, outdoors	L <sub>WA</sub>	86	dB (A)					
Contact details	Name and address of the manufacturer or its authorised representative.							
(1) For heat pump space heaters and heat pump combination heaters, the rated heat output Prated is equal to the design load for heating Pdesignh, and the rated heat output of a supplementary heater Psup is equal to the supplementary capacity for heating sup (Tj).								
(2) If Cdh is not determined by measurement then the default degradation coefficient is Cdh = 0,9.								

16127100A05390 MD18IU-015AW(DZ-1)



**MAIN OFFICE**

Blasco de Garay, 4-6  
08960 Sant Just Desvern  
(Barcelona)

Tel. +34 93 480 33 22  
<http://home.frigicoll.es/>  
<http://www.kaysun.es/en/>

**MADRID**

Senda Galiana, 1  
Polígono Industrial Coslada  
Coslada (Madrid)

Tel. +34 91 669 97 01  
Fax. +34 91 674 21 00  
[madrid@frigicoll.es](mailto:madrid@frigicoll.es)