

FICHA PRODUCTO SUITE MULTISISTEMA



UNIDAD INTERIOR MODELO AUREA II



CARACTERÍSTICAS

Modelo	KAY-S 26 DR8	KAY-S 35 DR8	KAY-S 52 DR8	KAY-S 71 DR8
Mando	KID- 02 S	KID- 02 S	KID- 02 S	KID- 02 S
Capacidad Frigorífica	2,64 kW	3,52 kW	5,28 kW	7,3 kW
Capacidad Calorífica	2,93 kW	3,81 kW	5,57 kW	7,64 kW
Tuberías Frigoríficas	ø1/4"- ø3/8"	ø1/4"- ø3/8"	ø1/4"- ø1/2"	ø3/8"- ø5/8"
Caudal de Aire (Al/Me/Bj)	521/429/259 m3/h	539/478/294 m3/h	750/505/420 m3/h	1050/750/560 m3/h
Presión Sonora (SILENCE)	20 dB	21 dB	23 dB	26 dB

CONEXIONADO ELÉCTRICO

Bornero Eléctrico

Cable de Interconexión (Alimentación Incluida)	(4+Tierra) x 2,5 mm ²
---	----------------------------------

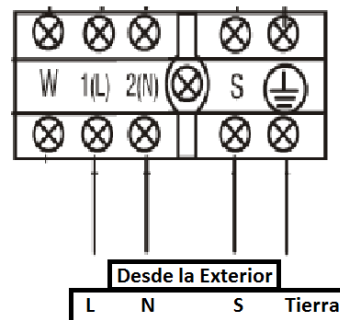

DIMENSIONES Y PESO DE LA UNIDAD

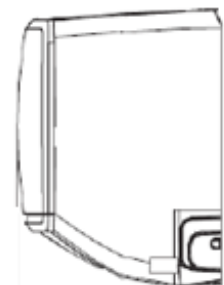

Modelo	KAY-S 26 DR8	KAY-S 35 DR8	KAY-S 52 DR8	KAY-S 71 DR8
Ancho	722 mm	802 mm	965 mm	1080 mm
Alto	290 mm	297 mm	319 mm	335 mm
Profundo	187 mm	189 mm	215 mm	226 mm
Peso	7.4 Kg	8,2 Kg	9 Kg	12 Kg